

PayCheck™ Slim PRINTER

Owner's Manual

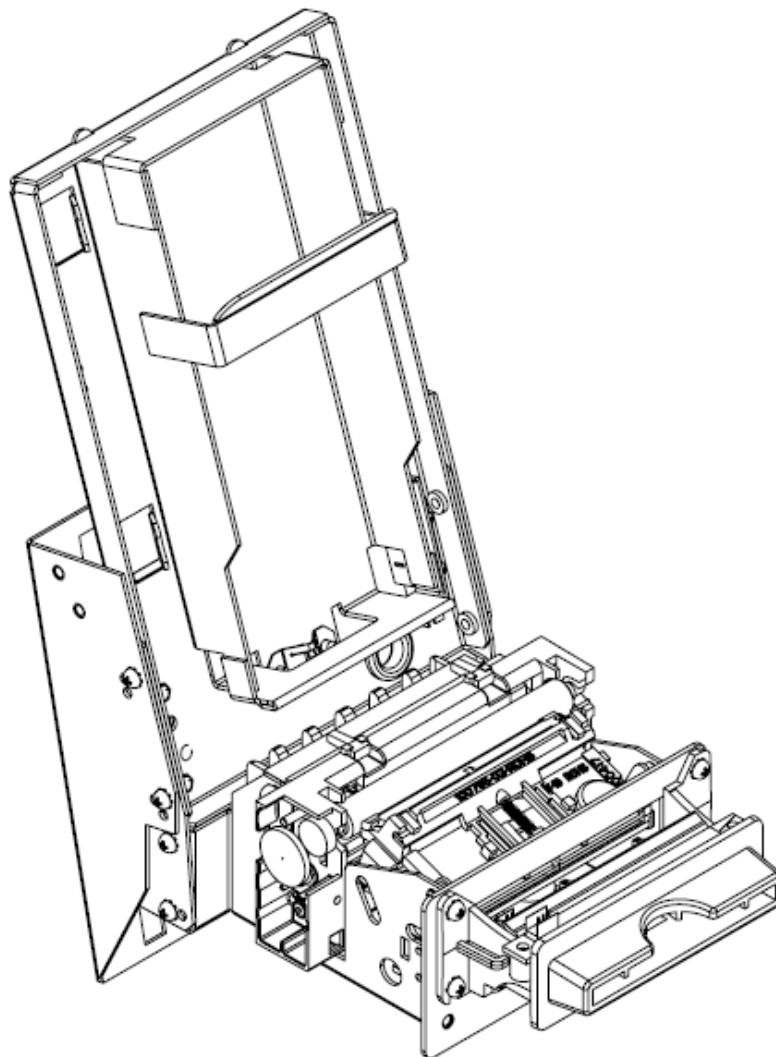

First Edition: January 2007
Latest Update August 2011
Document #979000-0000R



Legal Notices

Disclaimer

Information in this document is subject to change without notice. Consult your Nanoptix Inc. sales representative for information that is applicable and current. Nanoptix Inc. reserves the right to improve products as new technology, components, software, and firmware become available.

No part of this document may be reproduced or transmitted in any form or by any means, electronic or mechanical, for any purpose without the express written permission of Nanoptix Inc.

Copyright

Copyright 2003 by Nanoptix Inc.
Dieppe, New Brunswick Canada
All rights reserved
Printed in Canada
Confidential, Unpublished
Property of Nanoptix Inc.

Trademarks

Epson is registered trademark of Epson Corporation.

Windows is registered trademark of Microsoft Corporation.

Nanoptix is a trademark. Other trademarks and registered trademarks are the property of their respective holders.

Federal Communications Commission (FCC) Radio Frequency Interference Statement

Warning

Changes or modifications to this unit not expressly approved by the party responsible for compliance could void the user's authority to operate the equipment.

Information to the User

This equipment must be installed and used in strict accordance with the manufacturer's instructions. However, there is no guarantee that interference to radio communications will not occur in a particular commercial installation. If this equipment does cause interference, which can be determined by turning the equipment off and on, the user is encouraged to contact Nanoptix Inc. immediately.

Nanoptix Inc. is not responsible for any radio or television interference caused by unauthorized modification of this equipment or the substitution or attachment of connecting cables and equipment other than those specified by Nanoptix Inc. The correction of interferences caused by such unauthorized modification, substitution or attachment will be the responsibility of the user.



In order to ensure compliance with the Product Safety, FCC and CE marking requirements, you must use the power supply, power cord, and interface cable which were shipped with this product or which meet the following parameters:

Power Supply

A UL Listed power supply with standard 60Hz-50Hz, 100-240VAC input and 24VDC output equipped with AC line filtering, over-current and short-circuit protection must be used.

Use of this product with a power supply other than the Nanoptix Inc. power supply will require you to test the power supply and Nanoptix Inc. printer for FCC and CE mark certification.

Communication Interface Cable

An approved Nanoptix interface cable must be used with this product. Use of a cable other than Nanoptix approved product will require that you test the cable with the Nanoptix Inc. printer and your system for FCC and CE mark certification.

Power Cord

A UL listed, detachable power cord must be used. A power cord with Type SVT marking must be used. For applications outside the North America, power cords that meet the particular country's certification and application requirements should be used.

Use of a power cord other than described here may result in a violation of safety certifications that is in force in the country of use.



Table of Contents

1. About the Printer	1
1.1 Description of Printer	1
1.2 General specifications.....	2
1.3 Printer Controls.....	3
Printer Reset (Service use only).....	3
Paper Feed Button.....	4
LED.....	5
1.4 Changing Paper	6
1.5 Testing the Printer	7
1.6 Troubleshooting the Printer.....	8
Troubleshooting with LED	8
Printing Problems.....	8
Printer Does Not Work	9
2. Media and Supplies Guide.....	10
2.1 Media Specifications	10
2.2 Ordering Thermal Paper	10
2.3 Ordering Miscellaneous Supplies	11
Power Supply and Power Cord	11
Ordering Communication Cables.....	11
Communication Cables Pin-Out.....	12
APPENDIX A: Mechanical Drawings.....	13



Figures

FIGURE 1: NANOPTIX PAYCHECK SLIM PRINTER 1
FIGURE 2: PRINTER RESET 3
FIGURE 3: PAPER FEED BUTTON 4
FIGURE 4: LED POSITIONS 5
FIGURE 5: TEST TICKET 7
FIGURE 6: SIDE VIEW - MOUNTED IN POSITION A 13
FIGURE 7: SIDE VIEW - MOUNTED IN POSITION B 14
FIGURE 8: SIDE VIEW - MOUNTED IN POSITION C 15
FIGURE 9: FRONT VIEW 16
FIGURE 10: BACK VIEW 17



Tables

TABLE 1: SPECIFICATION	2
TABLE 2: TROUBLESHOOTING WITH LED	8
TABLE 3: TROUBLESHOOTING PRINTING PROBLEMS	8
TABLE 4: PRINTER DOES NOT WORK	9
TABLE 5: ORDERING THERMAL PAPER	10
TABLE 6: PART NUMBERS.....	11
TABLE 7: COMMUNICATION CABLES PART NUMBERS.....	11
TABLE 8: 14-PIN RS-232 UNIVERSAL INTERFACE PIN-OUT.....	12
TABLE 9: PIN-OUT AND SIGNALS OF FRONT MOLEX (FOR BEZEL)	12

1. About the Printer

1.1 Description of Printer

The Nanoptix PayCheck Slim Printer is extremely fast, quiet, and very reliable. With thermal printing technology, there is no ribbon cassette to change, and paper loading is very simple. The printer's intuitive design enables it to fit in very narrow cabinets.

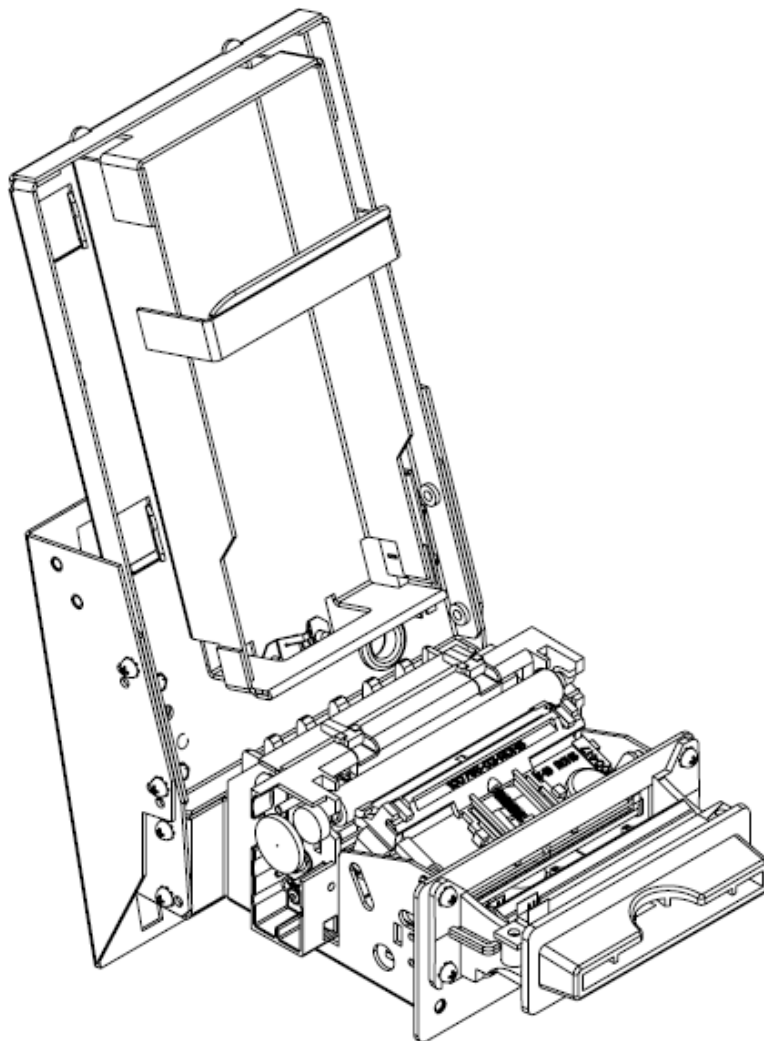

Figure 1: Nanoptix PayCheck Slim Printer



1.2 General specifications

Print Method	Direct Thermal
Resolution	8 dot/mm (203 dpi)
Print Width	64mm
Paper Width	65mm
Cartridge Size	200
Operating Temperature	0° to 50° C
Storage Temperature	-20° to 60° C
Operating Relative Humidity	5 to 90% RH at 50°C (non-condensing)
Communication Interface Options	Serial and USB
Memory/Firmware	8MB RAM, 2MB Flash and 1MBit EEPROM
Resident Character Sets	Arial Bold (6 sizes) Note: Other Character sets can be programmed quickly
Integrated Bar Codes	Interleaved 2 of 5, Code 39, Code 93, UPC-A & UPC-E, Codabar, EAN 8 & EAN 13, Code 128. Note: Other Bar Codes can be programmed quickly
Speed	Up to 200 mm/second (monochrome) Up to 125 mm/second (two-color mode)
Sensors	<ul style="list-style-type: none">• Paper in• Tray open• Top of form• Paper low
Human Interface	Drop-in paper loading, status LED, paper feed button
Dimensions	120mm width x 248.5mm height x 129mm depth
Weight	1.215 Kg

Table 1: Specification

1.3 Printer Controls

Printer Reset (Service use only)

To reset the printer, simply unplug and plug the cable. Once plugged in, the printer goes through a startup routine and resets itself.

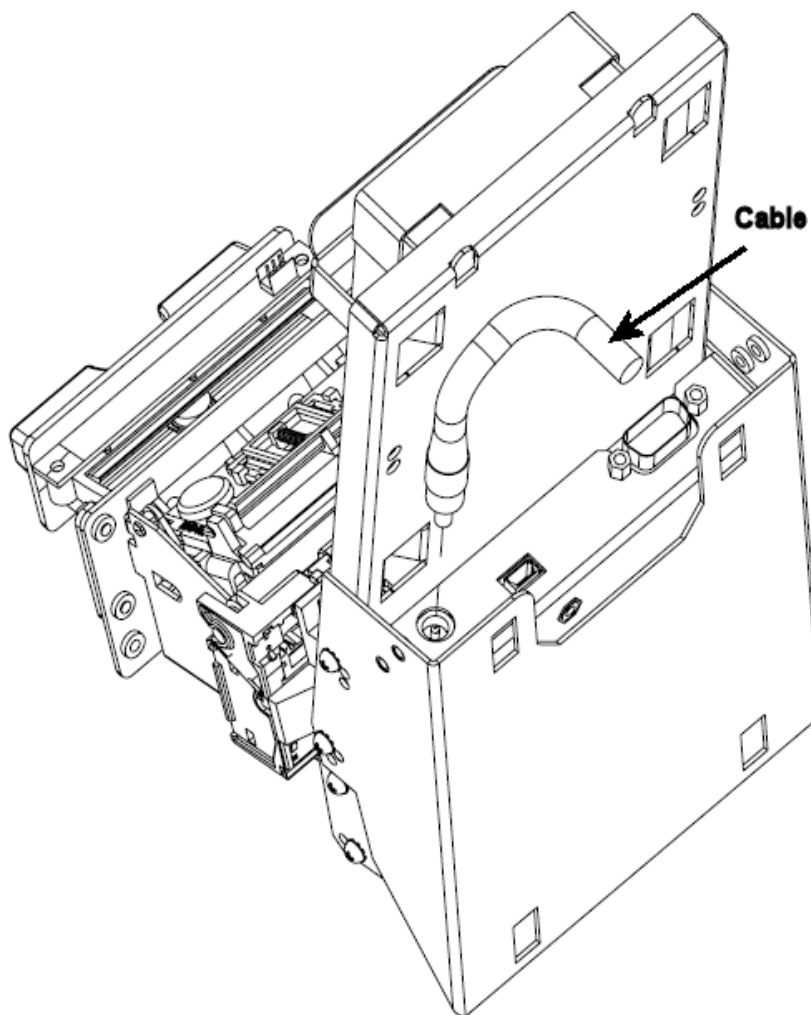

Figure 2: Printer Reset

Paper Feed Button

Press on the Paper Feed Button to advance the paper. The paper will automatically feed.

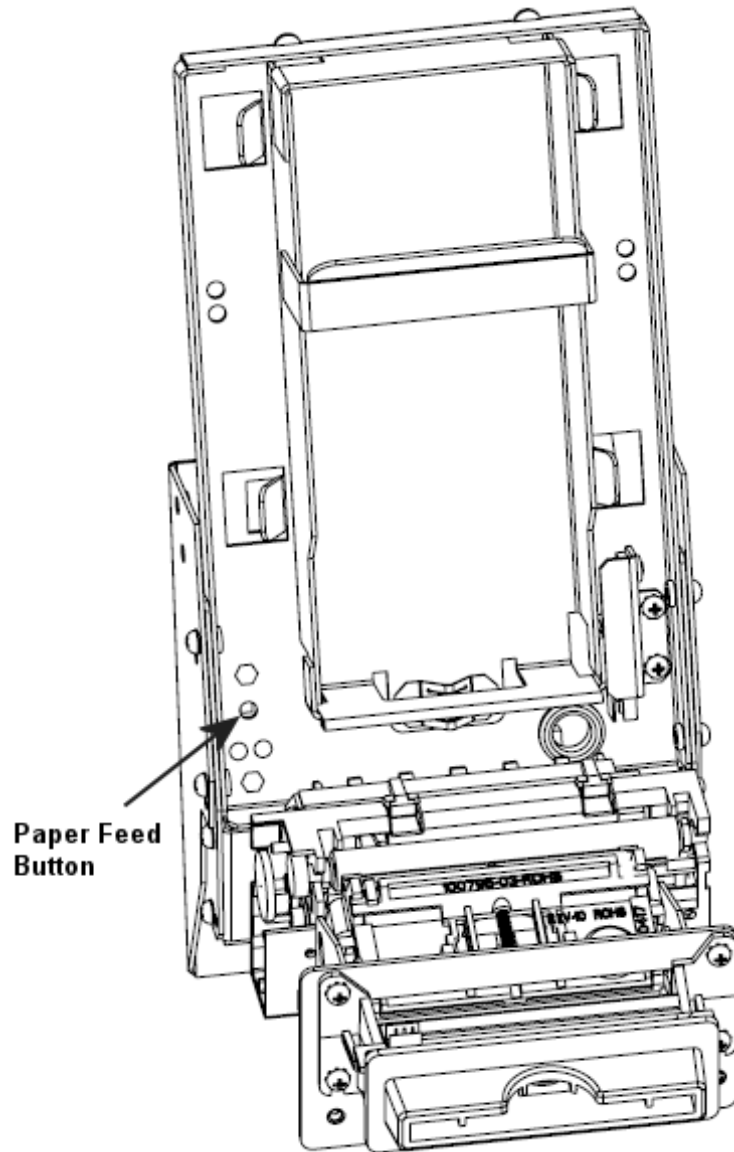

Figure 3: Paper Feed Button

LED

The LED on the main controller board shows the printer status. Please refer to section 1.6 for LED status and troubleshooting with LED. An optional external LED bezel can be connected through the front 3-pin Molex connector. The pin-out is described in section 2.3.

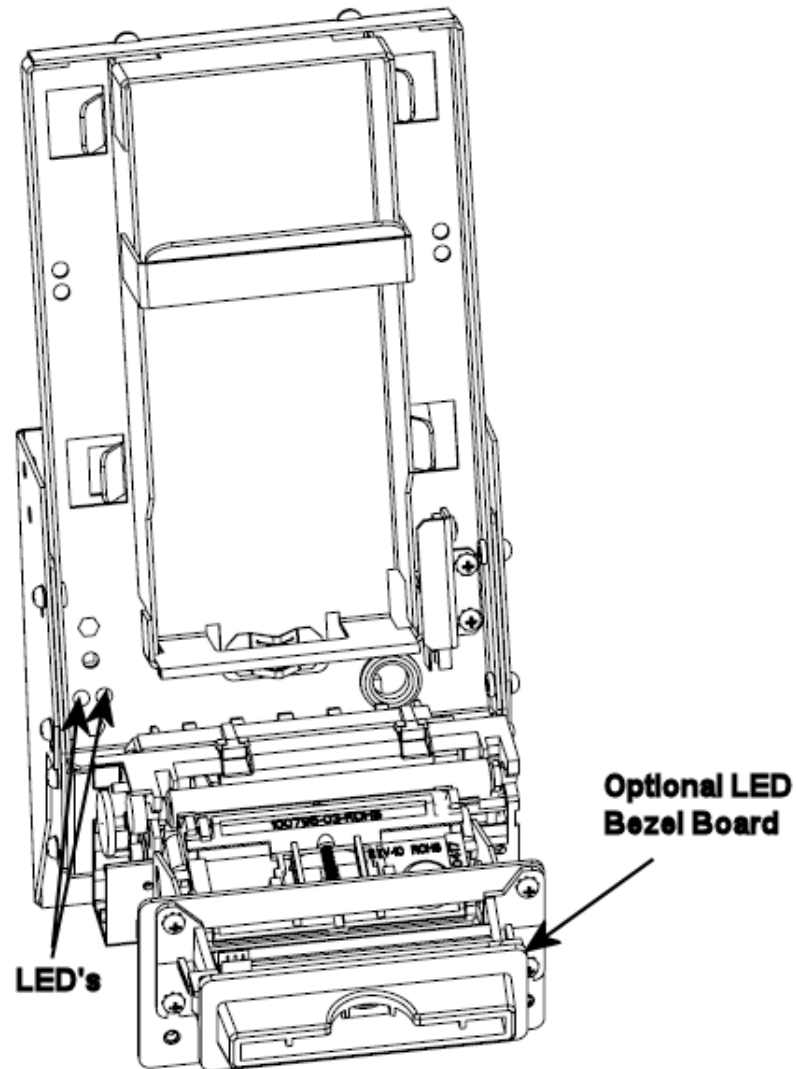

Figure 4: LED positions



1.4 Changing Paper

Change the paper when the paper is low or out.

Caution: Do not operate the printer or host computer if the printer runs out of paper. The printer will not operate without paper, but it may continue to accept data from the host computer. Because the printer cannot print any transactions, the data may be lost.

- 1) Remove ticket cartridge.
- 2) Drop ticket stack into ticket cartridge. The maximum stack that will fit in the ticket cartridge is 200.
- 3) Replace ticket cartridge.
- 4) Feed ticket into printer mechanism until resistance is met.
- 5) Paper will feed automatically; paper is loaded and printer is ready to print.



1.5 Testing the Printer

Run this test to check the printer. The test prints and cuts a resident test ticket. Verify this ticket to judge the printing quality.

To print the test ticket, power-on the printer while pressing and holding the Paper Feed Button (figure 3) for approximately 3 seconds. A test ticket similar to the one below will be printed approximately 5 seconds later. Press the paper feed button once more and the ticket will feed. Pressing the button again will result in blank tickets.

```
Model:                PAYCHECK 3
Firmware:             PAY-1.79U
Protocol:             NTL
COMMUNICATION
Interface:            Serial
Baud Rate:            9600
Data Bits:            8
Parity:               NONE
Handshaking:          PRT+RTS
Print mode:           NTL
Aux Port:             Disabled
PRINT CONTROL
Print Method:         No HPQ
Speed:                150 mm/sec
Black Bar Index:      Right
No HPQ Burn time:    275 us
Motor Current:        2
Real-Time Command:    Enabled
Auto Reset Status:    Enabled
PRINTER ENVIRONMENT CONDITIONS
Voltage:              23.8 Volts
Temperature:          24 Celcius
SYSTEM RESOURCES
FLASH:  -Used:        0
        -Free:         65535
LIBRARY INVENTORY
Templates: 0,1,2,3,4,5,6,7,8,9,A,B
Regions:1,2,3,4,5,6,7,8,h,9,A,B,C,D,E,F,G,I,J,K,L,N,O,P,Q,R,
S,T, U,Z,X,a,b,c,d,e,f,g,i,j,k,l,m,n,o,p,q,
Fonts:0,1,2,3,4,5,7,8,9,P,E,A,B
Graphics:
MANUFACTURING INFORMATION
Printer ID:
Date Code:            fffffff
A to D: 03b4, 020e, 01cc, 03fe
Dip Switch Config (1234) : 0000
STATUS:
*s0|PAY-1.79U|@|@|@|H|@|P|*
```

Figure 5: Test Ticket



1.6 Troubleshooting the Printer

The printer is simple and generally trouble-free, but from time to time problems may occur. Follow these procedures to determine the cause and resolution of any problems the printer may be having. If the procedures in this section do not correct the problem, contact a service representative.

Troubleshooting with LED

Error LED (Red)	Status LED (Green)	Condition
OFF	ON	Printer Powered or Ready
ON	ON	Paper Out
MED BLINK	ON	Temperature Error
SLOW BLINK	ON	Voltage Error (Over 26.2 VDC)
FAST BLINK	ON	Print Head Error
FAST BLINK	ON	Missing Black Index Mark
FAST BLINK	ON	Paper Jam

Table 2: Troubleshooting with LED

Printing Problems

Problem	Possible Causes	What to Do
Receipt does not come out all the way.	Paper is jammed.	Open the tray and clear any jammed paper.
Printer starts to print, but stops while the receipt is being printed.	Paper is jammed.	Open the tray and clear any jammed paper.
Print is light or spotty.	Paper tickets loaded incorrectly.	Check that the paper is loaded properly.
	Thermal printhead is dirty.	Use recommended thermal receipt paper. Clean printhead at recommended intervals.
Vertical column of print is missing.	Change the paper stack to make sure the thermal coating is not the source. If it does not solve the problem, it could indicate a problem with the printer electronics.	Contact your authorized service representative.
One side or portion of ticket has not been printed	Change the paper stack to make sure the thermal coating is not the source. If it does not solve the problem, it could indicate a problem with the printer electronics.	Contact service representative.

Table 3: Troubleshooting Printing Problems



Printer Does Not Work

Problem	Possible Causes	What to Do
Printer Does Not Function When Turned On.	Printer not plugged in.	Check that printer cables are properly connected on both ends.
		Check that the host or power supply is getting power.

Table 4: Printer Does Not Work



2. Media and Supplies Guide

2.1 Media Specifications

The printer requires qualified thermal paper with the following specifications:

- 2.1.1 – Ticket dimensions shall be 65+/- 1mm (2.56 in +/- .040”) x 156 +/-1 mm (6.14 +/- 0.040”)
- 2.1.2 – Paper stock shall be furnished in bulk stacks of 200 tickets.
- 2.1.3 – Tickets shall be attached (chained) to one another at 156mm intervals and supplied in “fan-folded” format
- 2.1.4 – Attachment between tickets shall be made with perforations across the paper width (65mm).
- 2.1.5 – The perforations shall also define the fold point in the paper stock.
- 2.1.6 – Perforation (burst) strength, or pull force, shall be 1.3+/- 0.4 lbs (0.59 +/-0.18 Kg)

2.2 Ordering Thermal Paper

We recommend the following paper grade produced by Appleton and Kanzaki Specialty Papers. There are a number of paper converters qualified to supply this paper, provided the stacks are from these recommended grades. We would be happy to provide a quote for qualifying additional grades not listed below.

Manufacturer	Numbers	Nanoptix part no	Paper Grade
Appleton Papers	Tel:920-991-8438	100505-3024 (200 stack)	Royale 800-4.5
Kanzaki Specialty Papers (USA)	Tel:888-526-9254 Fax: 413-731-8864	100505-3012 (200 stack)	TO-381-N

Table 5: Ordering Thermal Paper



2.3 Ordering Miscellaneous Supplies

Power Supply and Power Cord

Contact your sales representative to order the power supply listed in the table.

Part	Part Number
14-Pin Molex Power Supply (24VDC, 2.5A max., 60W)	210007-0202R
3-Pin Molex Power Supply (24VDC, 2.5A max., 60W)	210007-0401R
Power cord (North American)	102080-0014
Power cord (continental Europe)	102080-0013

Table 6: Part Numbers

Ordering Communication Cables

Contact your sales representative to order the communication cables listed in the table. The numbers are for reference only. Suppliers may use other numbers.

Part	Part Number
RS232 communication and power cable (14 pin Molex to DB-9) to DC Jack	210001-0001R

Table 7: Communication Cables Part Numbers



Communication Cables Pin-Out

The tables below detail the connection pin-out for the Serial interface (14-pin Molex) on the printer side.

Pin	Signal Name	Printer I/O	Host I/O	Printer Function
1	Reset	Input	Output	Resets Printer
2	PRT_AUX_RXD	Input	Output	Auxiliary Receive
3	VAUX	Input	Output	Auxiliary Power
4	PRT_AUX_TXD	Output	Input	Auxiliary Transmit
5	Signal Ground	Signal Ground	Signal Ground	Signal Ground
6	24V	Power Input	n/a	Power Input
7	Signal Ground	Signal Ground	n/a	Signal Ground
8	24V	Power Input	n/a	Power Input
9	Bezel_pwm	24V Output	n/a	Bezel Driver
10	Signal Ground	Signal Ground	Signal Ground	Signal Ground
11	PRT_RS232_RXD	Input	Output	Data Receive
12	PRT_RS232_TXD	Output	Input	Data Transmit
13	PRT_Status	Output	Input	Printer Ready
14	PRT_RS232_RTS	Output	Input	Handshake

Table 8: 14-Pin RS-232 Universal Interface Pin-Out

The tables below detail the connection pin-out for the front Bezel Connector (3-pin Molex).

Pin	Signal	Printer I/O
1	Bezel PWM	Output
2	24VDC	Output
3	GND	GND

Table 9: Pin-Out and signals of Front Molex (for Bezel)

APPENDIX A: Mechanical Drawings

In order to be able to accommodate as many slim cabinets as possible, the PayCheck Slim printer has three different mounting positions. The three mounting options (position A, B and C) along with their dimensions are described in the following pages. The rear support bracket (Figure 11) and mounting points remain the same for all three mounting options.

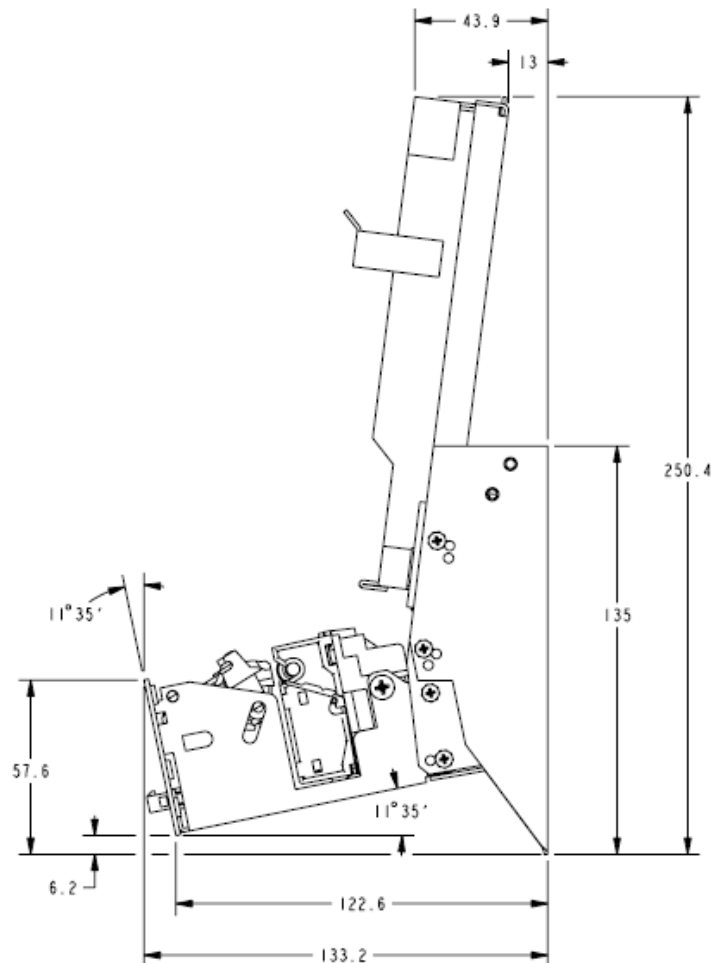

Figure 6: Side View - Mounted in Position A

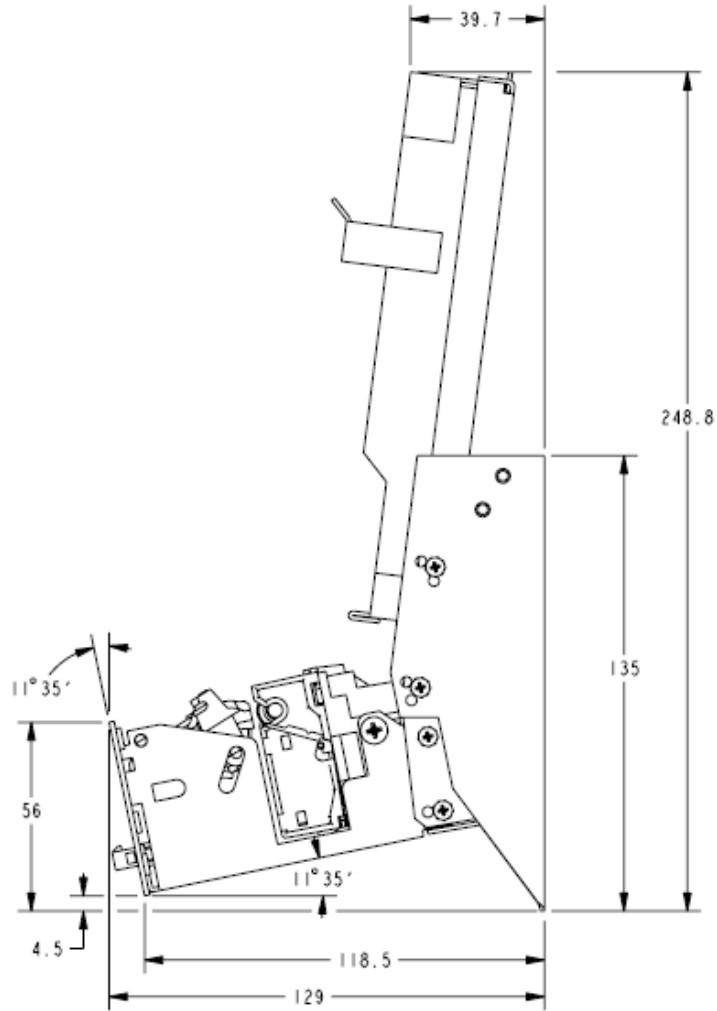

Figure 7: Side View - Mounted in Position B

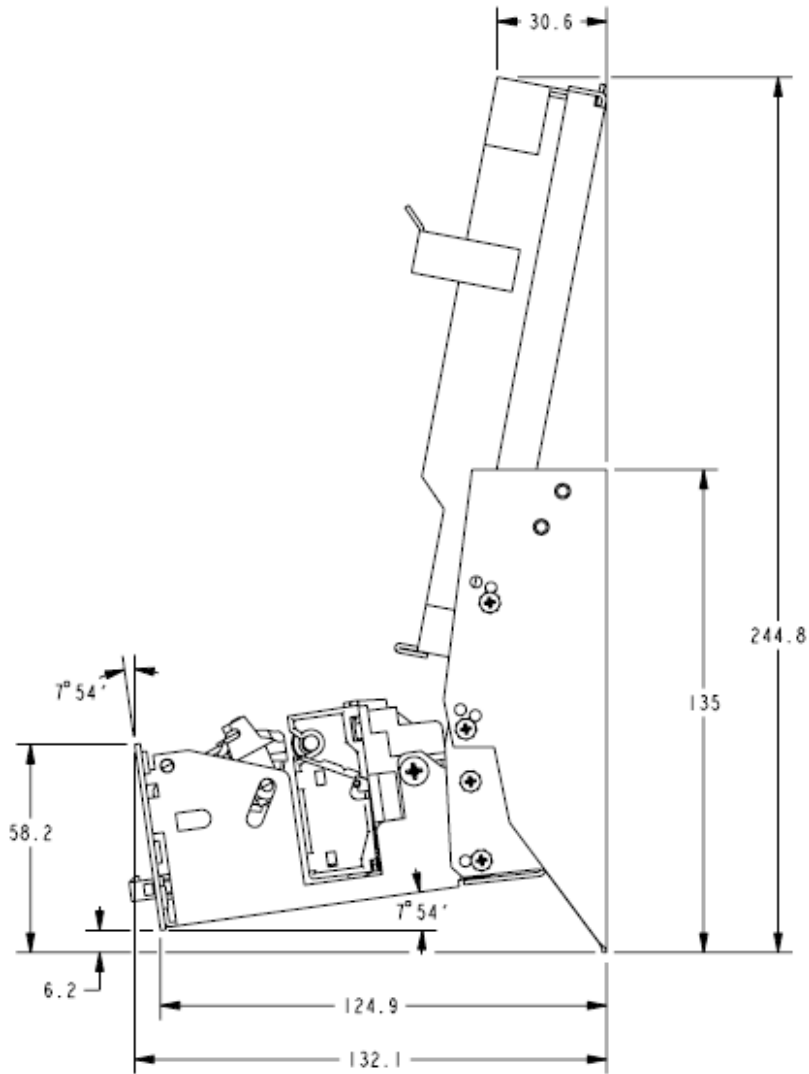

Figure 8: Side View - Mounted in Position C

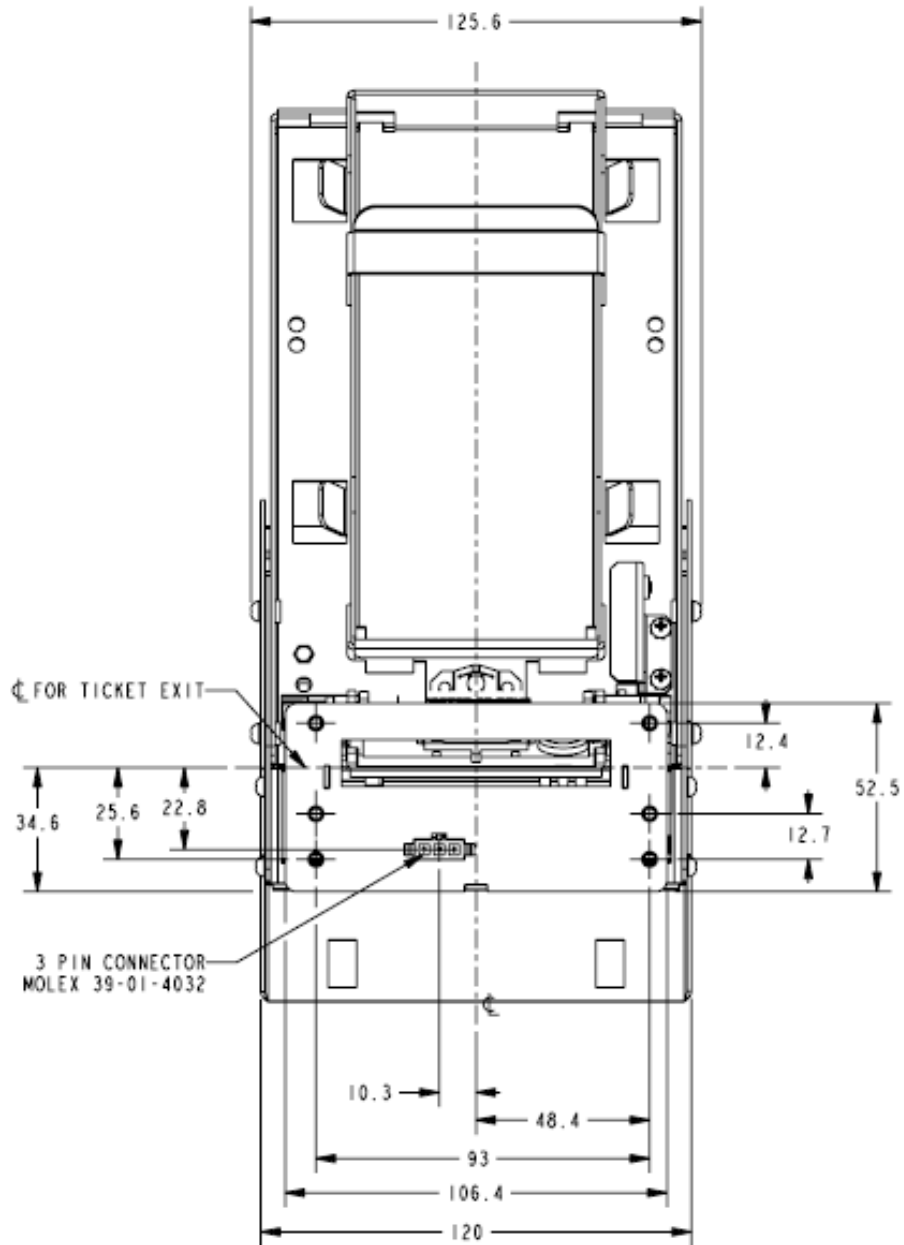

Figure 9: Front View

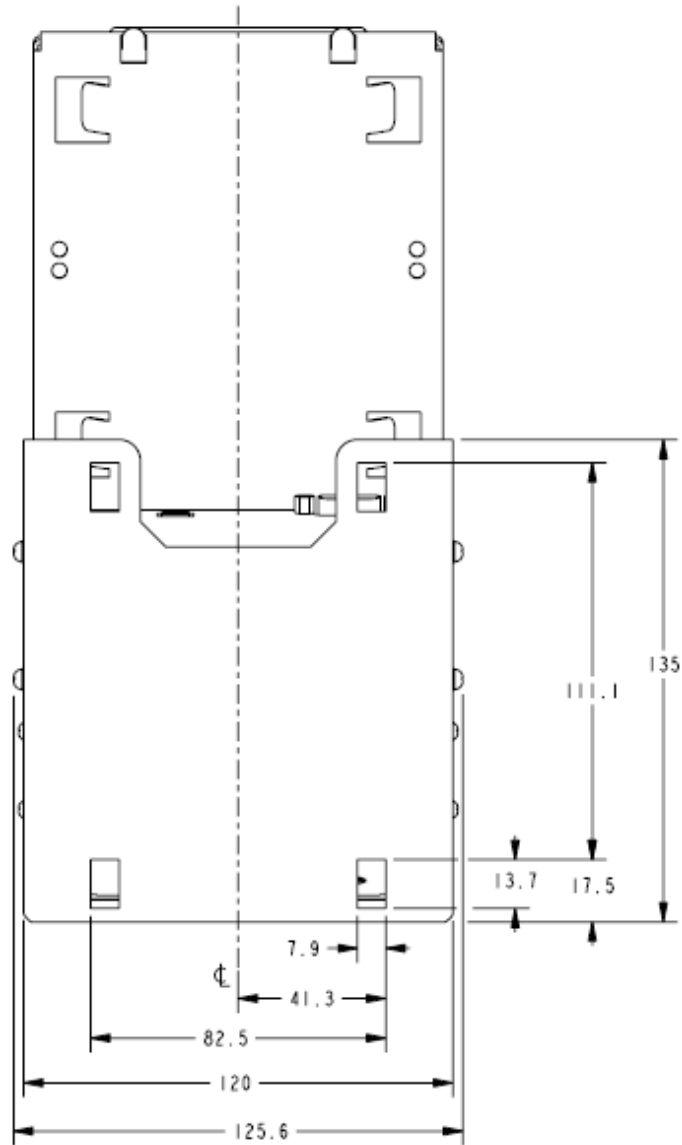

Figure 10: Back View