

# PayCheck™ 4 PRINTER

## *Owner's Manual*



First Edition: December 2002  
Last Revision: April 26, 2012  
Document #720005-0000





## Legal Notices

### Disclaimer

Information in this document is subject to change without notice. Consult your Nanoptix Inc. sales representative for information that is applicable and current. Nanoptix Inc. reserves the right to improve products as new technology, components, software, and firmware become available.

No part of this document may be reproduced or transmitted in any form or by any means, electronic or mechanical, for any purpose without the express written permission of Nanoptix Inc.

### Copyright

Copyright 2003 by Nanoptix Inc.  
Dieppe, New Brunswick Canada  
All rights reserved  
Printed in Canada  
Confidential, Unpublished  
Property of Nanoptix Inc.

### Trademarks

Epson is registered trademark of Epson Corporation.

Windows is registered trademark of Microsoft Corporation.

Nanoptix is a trademark. Other trademarks and registered trademarks are the property of their respective holders.

### Federal Communications Commission (FCC) Radio Frequency Interference Statement

#### Warning

Changes or modifications to this unit not expressly approved by the party responsible for compliance could void the user's authority to operate the equipment.

#### Note

This equipment has been tested and found to comply with the limits for a Class B digital device, pursuant to Part 15 of the FCC Rules. These limits are designed to provide reasonable protection against harmful interference when the equipment is operated in a commercial environment. This equipment generates, uses, and can radiate radio frequency energy and, if not installed and used in accordance with the instruction manual, may cause harmful interference to radio communications. Operation of this equipment in a residential area is likely to cause harmful interference in which case the user will be required to correct the interference at his own expense.

### Industry Canada (IC) Radio Frequency Interference Statement

This Class B digital apparatus meets all requirements of the Canadian Interference-Causing Equipment Regulations.

*Cet appareil numérique de la classe B respecte toutes les exigences du Règlement sur le matériel brouilleur du Canada.*



### **Information to the User**

This equipment must be installed and used in strict accordance with the manufacturer's instructions. However, there is no guarantee that interference to radio communications will not occur in a particular commercial installation. If this equipment does cause interference, which can be determined by turning the equipment off and on, the user is encouraged to contact Nanoptix Inc. immediately.

Nanoptix Inc. is not responsible for any radio or television interference caused by unauthorized modification of this equipment or the substitution or attachment of connecting cables and equipment other than those specified by Nanoptix Inc. The correction of interferences caused by such unauthorized modification, substitution or attachment will be the responsibility of the user.

In order to ensure compliance with the Product Safety, FCC and CE marking requirements, you must use the power supply, power cord, and interface cable which were shipped with this product or which meet the following parameters:

#### **Power Supply**

CSA/UL Listed power supply with standard 60Hz-50Hz, 100-240VAC input and 24VDC output equipped with AC line filtering, over-current and short-circuit protection.

Use of this product with a power supply other than the Nanoptix Inc. power supply will require you to test the power supply and Nanoptix Inc. printer for FCC and CE mark certification.

#### **Communication Interface Cable**

An approved Nanoptix interface cable must be used with this product. Use of a cable other than Nanoptix approved product will require that you test the cable with the Nanoptix Inc. printer and your system for FCC and CE mark certification.

#### **Power Cord**

CSA/UL listed, detachable power cord must be used. A power cord with Type SVT marking must be used. For applications outside the North America, power cords that meet the particular country's certification and application requirements should be used.

Use of a power cord other than described here may result in a violation of safety certifications that is in force in the country of use.



## Table of Contents

<b>1. About the Printer</b> .....	<b>1</b>
1.1 Description of Printer .....	1
1.2 General specifications .....	2
1.3 Printer Controls.....	3
Printer Reset (Service use only) .....	3
Paper Feed Button .....	3
Firmware Selector DIP switches .....	4
LED .....	5
1.4 Mounting .....	6
1.5 Changing Paper .....	7
1.6 Testing the Printer .....	8
1.7 Troubleshooting the Printer.....	9
Troubleshooting with LED .....	9
Printing Problems .....	9
Printer Does Not Work .....	10
<b>2. Media and Supplies Guide</b> .....	<b>11</b>
2.1 Media Specifications .....	11
2.2 Ordering Thermal Paper .....	11
2.3 Ordering Miscellaneous Supplies .....	14
Power Supply and Power Cord .....	14
Ordering Communication Cables.....	14
Ordering Bezels.....	15
Ordering Trays.....	15
Communication Cables Pin-Out.....	16
<b>APPENDIX A: Mechanical Drawings</b> .....	<b>17</b>
<b>Nanoptix Contact Information</b> .....	<b>19</b>

## Figures

<b>FIGURE 1: NANOPTIX PAYCHECK PRINTER .....</b>	<b>1</b>
<b>FIGURE 2: PRINTER RESET .....</b>	<b>3</b>
<b>FIGURE 3: PAPER FEED BUTTON .....</b>	<b>3</b>
<b>FIGURE 4: DIP SWITCH .....</b>	<b>4</b>
<b>FIGURE 5: LED POSITIONS .....</b>	<b>5</b>
<b>FIGURE 6: HORIZONTAL AND VERTICAL MOUNTING POSITIONS.....</b>	<b>6</b>
<b>FIGURE 7: LOADING PAPER.....</b>	<b>7</b>
<b>FIGURE 8: SAMPLE TEST TICKET.....</b>	<b>8</b>
<b>FIGURE 9: THERMAL PAPER SPECIFICATIONS .....</b>	<b>12</b>
<b>FIGURE 10: TICKET STACK AND BANDING EXAMPLE .....</b>	<b>13</b>
<b>FIGURE 11: MECHANICAL DIMENSIONS – PAYCHECK 4 PRINTER RIGHT SIDE VIEW.....</b>	<b>17</b>
<b>FIGURE 12: MECHANICAL DIMENSIONS – PAYCHECK 4 PRINTER BOTTOM VIEW .....</b>	<b>17</b>
<b>FIGURE 13: MECHANICAL DIMENSIONS – PAYCHECK 4 PRINTER FRONT VIEW.....</b>	<b>18</b>
<b>FIGURE 14: MECHANICAL DIMENSIONS – PAYCHECK 4 PRINTER TOP VIEW.....</b>	<b>18</b>
<b>FIGURE 15: MECHANICAL DIMENSIONS – PAYCHECK 4 PRINTER LEFT SIDE VIEW .....</b>	<b>19</b>



## Tables

TABLE 1: SPECIFICATION .....	2
TABLE 2: TROUBLESHOOTING WITH LED .....	9
TABLE 3: TROUBLESHOOTING PRINTING PROBLEMS .....	9
TABLE 4: PRINTER DOES NOT WORK .....	10
TABLE 5: ORDERING THERMAL PAPER .....	11
TABLE 6: PART NUMBERS.....	14
TABLE 7: COMMUNICATION CABLES PART NUMBERS.....	14
TABLE 8: BEZEL TYPES .....	165
TABLE 9: TRAYSIZES .....	165
TABLE 10: 14-PIN UNIVERSAL INTERFACE PIN-OUT.....	16
TABLE 11: PIN-OUT AND SIGNALS OF FRONT MOLEX (FOR BEZEL).....	16

# 1. About the Printer

## 1.1 Description of Printer

The Nanoptix PayCheck 4 printer, also known as Triton, is extremely fast, quiet, and very reliable. With thermal printing technology, there is no ribbon cassette to change, and paper loading is extremely simple. The printer is small enough to fit almost anywhere and is easy to use with the ticket exiting from the front.



**Figure 1: Nanoptix PayCheck Printer**

## 1.2 General specifications

<b>Print Method</b>	Direct Thermal
<b>Resolution</b>	8 dot/mm (203 dpi)
<b>Print Width</b>	64mm
<b>Paper Width</b>	65mm
<b>Cartridge Size</b>	200, 400, 600, 800
<b>Operating Temperature</b>	0°C to 50°C
<b>Storage Temperature</b>	-40°C to +75°C
<b>Operating Relative Humidity</b>	5% to 90% RH at 50°C (non-condensing)
<b>Communication Interface Options</b>	Bidirectional RS-232C -Dedicated USB Communication -Dedicated USB Maintenance Port
<b>Memory/Firmware</b>	8MBytes RAM, 2MBytes Flash and 8kBytes of FRAM
<b>Resident Character Sets</b>	Arial Bold (6 sizes) Note: Other Character sets can be programmed quickly
<b>Integrated Bar Codes</b>	UPC-A, UPC-E, interleaved 2 of 5, Code 39, Code 128, EAN 8, EAN 13. Note: Other Bar Codes can be programmed quickly
<b>Speed</b>	Up to 200 mm/second (monochrome) Up to 125 mm/second (two-color mode)
<b>Sensors</b>	<ul style="list-style-type: none"> <li>• Paper in</li> <li>• Tray open</li> <li>• Top of form</li> <li>• Paper low</li> </ul>
<b>Real Time Clock</b>	Battery backed-up (Silver oxide coin cell battery)
<b>Human Interface</b>	Drop-in paper loading, status LED, paper feed button
<b>Duty Cycle (max.)</b>	5 tickets per minute
<b>Dimensions</b>	113mm width x 67mm height x 286mm depth
<b>Weight</b>	1.5kg
<b>Immunity</b>	EN 55024 Information Technology Equipment
<b>Emission Standards</b>	United States - FCC Part 15 Subpart A Canada - Industry Canada ICES-003 Europe – EN 55022 Class B emissions Information Technology Equipment
<b>Durability (Thermal head)</b>	100 Km of paper transport or 100 Million pulses per element with approved paper
<b>Maintenance</b>	Approved IPA alcohol felt-tip cleaner or cleaning cards for cleaning thermal head
<b>Safety</b>	Intertek Certified (ETL listed) Control Number: 3086884

Table 1: Specification

## 1.3 Printer Controls

### Printer Reset (Service use only)

To reset the printer, simply unplug and plug the cable. Once plugged in, the printer goes through a startup routine and resets itself.

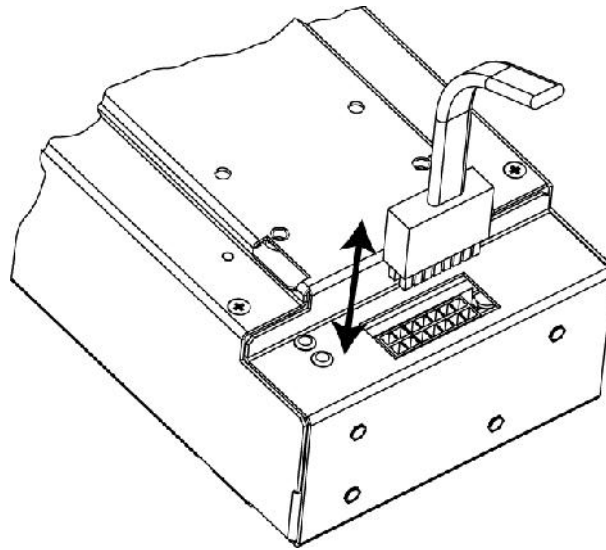

Figure 2: Printer Reset

### Paper Feed Button

Use the Paper Feed Button to advance the paper. The paper will automatically feed. Tear off the form that has been fed and the printer will be ready to print on a full form.

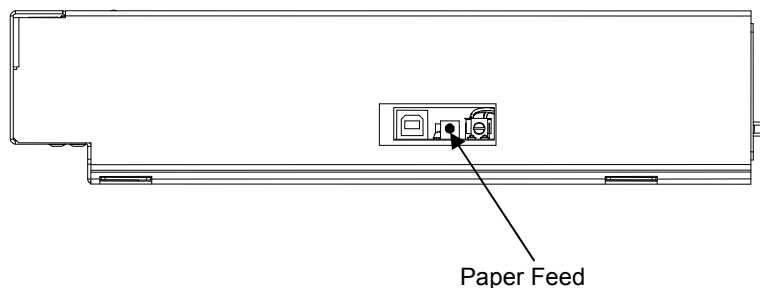

Figure 3: Paper Feed Button

### Firmware Selector DIP switches

Remove the ticket tray to access the firmware selector DIP switches. Various firmware and settings configurations are available by selecting the 16 different DIP switch combinations.

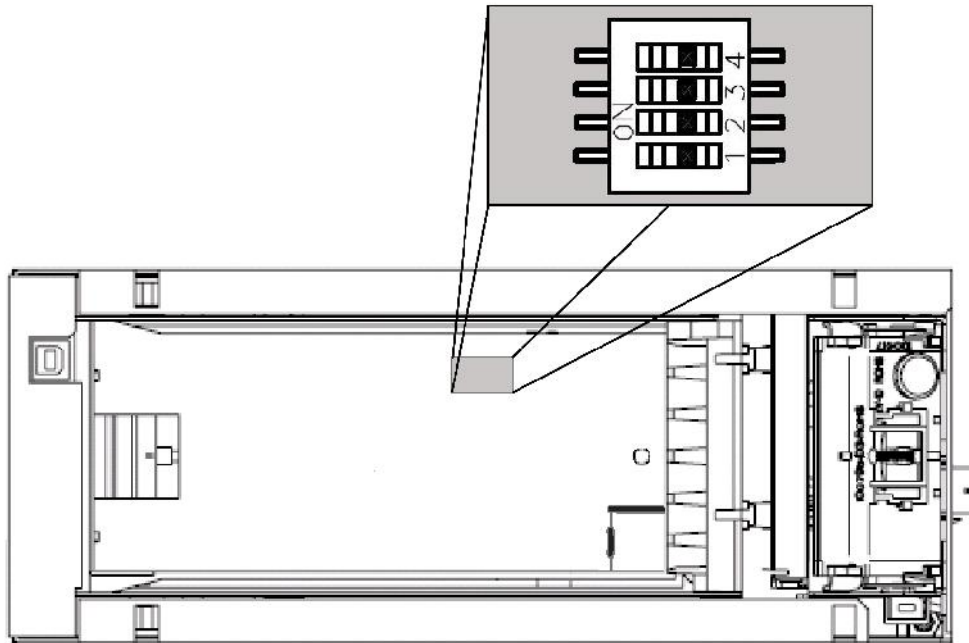

Figure 4: DIP Switch

## LED

The LED on the main controller board shows the printer status. Please refer to section 1.6 for LED status and troubleshooting with LED. An external LED can be connected through the front 3-pin Molex connector. The pin-out is described in section 2.3.

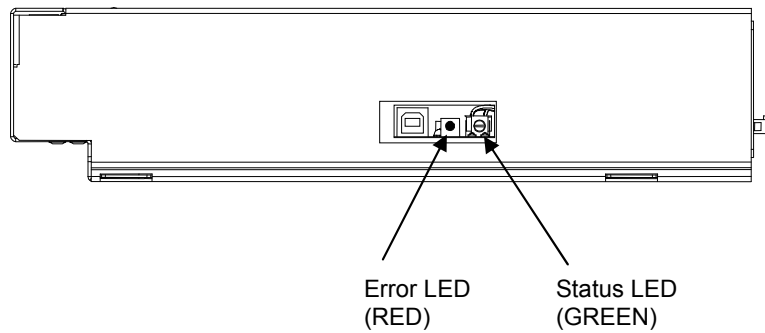
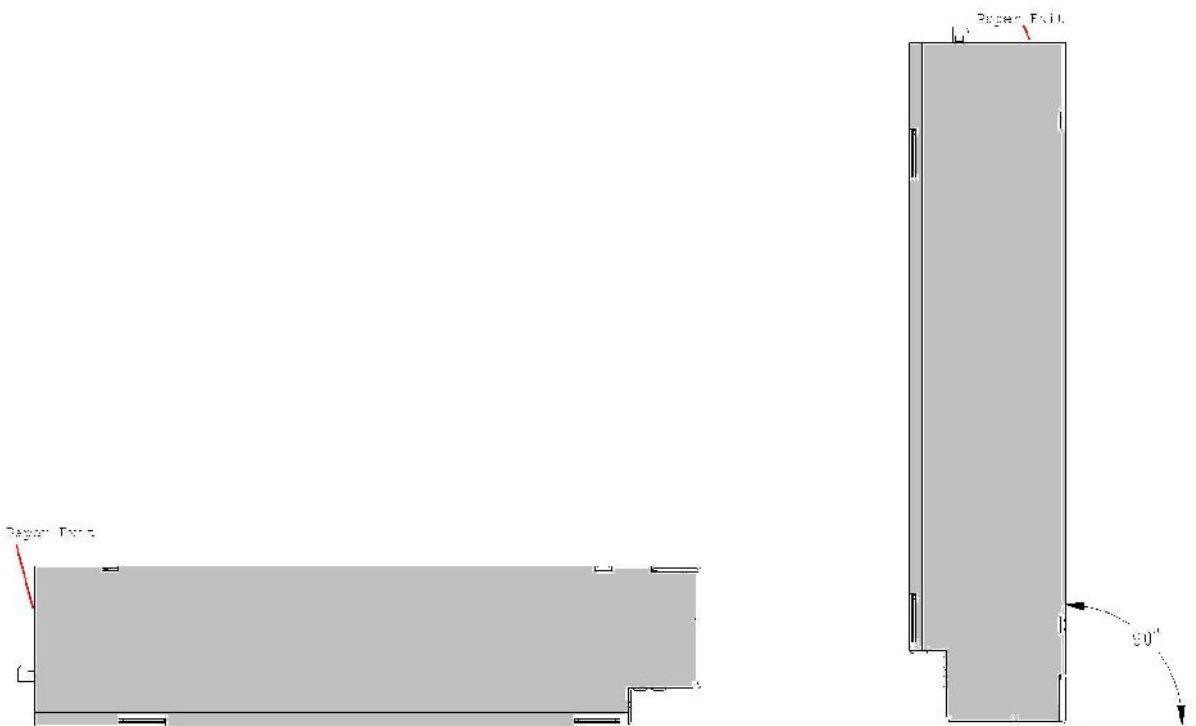

Figure 5: LED positions

## 1.4 Mounting

The Paycheck <sup>TM</sup> 4 must be mounted using the 4 threaded mounting fasteners or the 4 through-holes located under the printer (see Appendix A – Bottom View). Care must be taken so the fasteners do not damage the flex cable during installation or operation. The printer can be installed up to 90 degrees from horizontal (paper exit facing up), provided the proper paper tray is installed. For angles of 45-90 degrees, a specially designed paper tray must be used to avoid paper jams. The printer and thermal head warranty are unaffected under these conditions.



**Figure 6: Horizontal and Vertical Mounting positions**

## 1.5 Changing Paper

Change the paper when the paper is low or out.

**Caution:** Do not operate the printer or host computer if the printer runs out of paper. The printer will not operate without paper, but it may continue to accept data from the host computer. Because the printer cannot print any transactions, the data may be lost.

Load a stack of tickets into the printer. The maximum stack that will fit in the ticket cartridge is 200, 400 or 800 tickets depending on the cartridge option that was purchased with your printer.

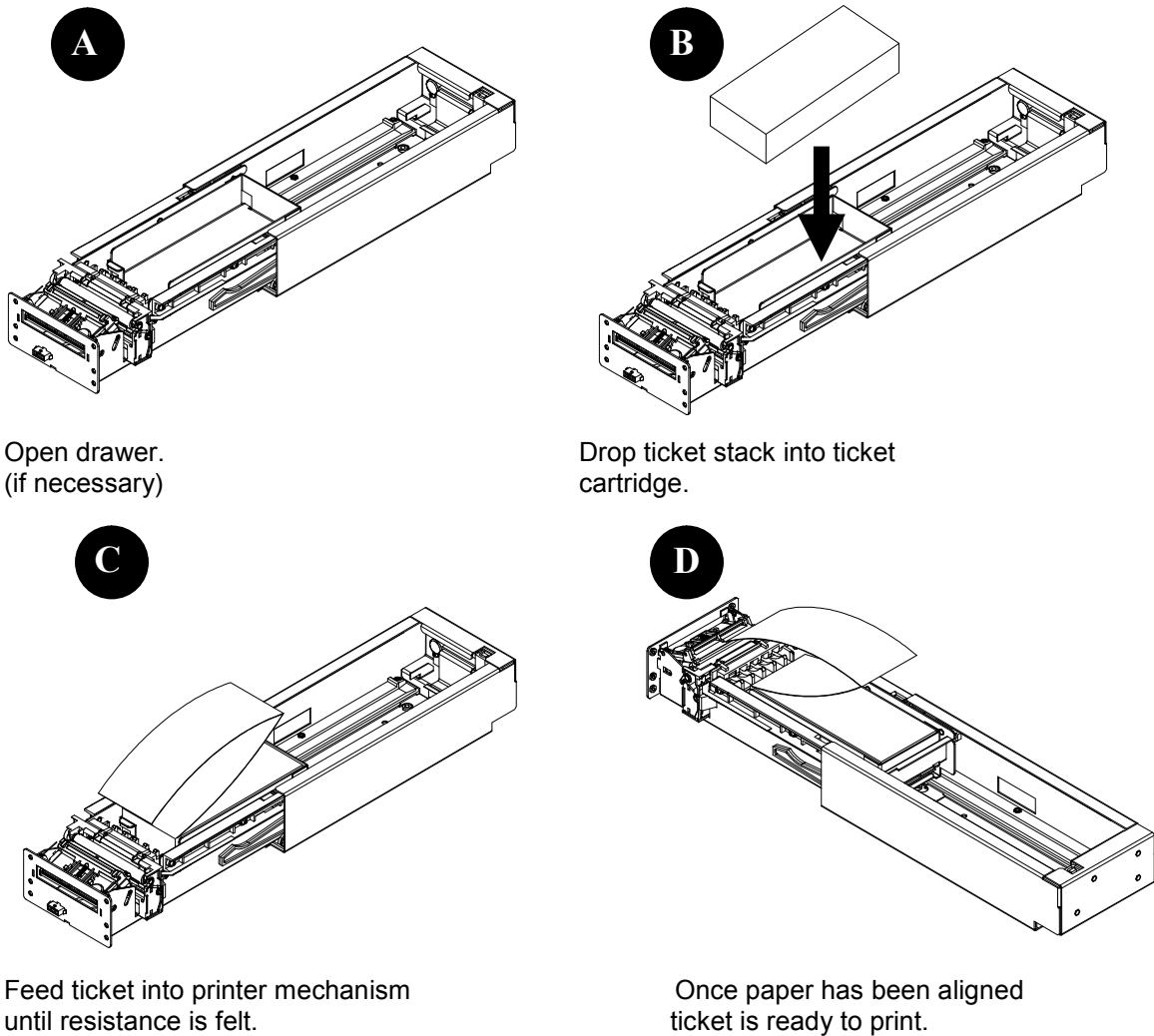

Figure 7: Loading Paper

## 1.6 Testing the Printer

Run this test to check the printer. The test prints and cuts a resident test ticket. Verify this ticket to judge the printing quality.

Model:	PAYCHECK 4
Firmware:	PAY-4.82H (0x1CB1)
User Version:	S R.2.4.0
Protocol:	NTL
COMMUNICATION	
Interface:	Serial
Baud Rate:	38400,8,NONE
Handshaking:	PRT+RTS
Print mode:	NTL
Back USB :	Fw Controlled
PRINT CONTROL	
Speed:	100 mm/sec
Black Bar Index:	Right
No HPQ Burn Time:	250 us
Motor Current:	2
Real-Time Command:	Enabled
Auto Reset Status:	Disabled
Validation Bit:	Smart TOF
Save Valid Bit:	Enabled
PRINTER ENVIRONMENT CONDITIONS	
Voltage:	24.7 Volts
Temperature:	25 Celcius
SYSTEM RESOURCES	
FLASH Used=00000	RAM: Used=00000
Free=65535	Free=65535
LIBRARY INVENTORY (CUSTOM)	
Templates:	6
Regions:	1,2,3,4,5,6,7,8,h,9,A,B,C,D, E,F,G,I,J,K,L,N,O,P,Q,R,S,T ,U,Z,X,a,b,c,d,e,f,g,i,j,k,l,m,n ,o,p,q,s,t,u,v,w 0,1,2,3,4,5,6,7,8,9,A,B
Fonts :	
Graphics:	
MANUFACTURING INFORMATION	
Printer ID:	P312681
Date Code:	20100215
A to D:	03d8, 021a, 0231, 03c6
Dip Switch Config (1234):	0000
Status:	*S 0 PAY-4.82H @ @ @  @ P *

**Figure 8: Sample Test Ticket**

To print the test ticket, power-on the printer while pressing and holding the Paper Feed Button for approximately 3 seconds. A test ticket similar to the one above will be printed approximately 5 seconds after. Press the paper feed button once more and the ticket will feed. Pressing the button again will result in blank tickets.

## 1.7 Troubleshooting the Printer

The printer is simple and generally trouble-free, but from time to time problems may occur. Follow these procedures to determine the cause and resolution of any problems the printer may be having. If the procedures in this section do not correct the problem, contact a service representative.

### Troubleshooting with LED

Error LED (Red)	Status LED (Green)	Condition
OFF	ON	Printer Ready
ON	OFF	Paper Out
MED BLINK	OFF	Temperature Error
SLOW BLINK	OFF	Voltage Error (Over 26.2 VDC)
FAST BLINK	ON	Print Head Error
FAST BLINK	ON	Missing Black Index Mark
FAST BLINK	ON	Paper Jam

**Table 2: Troubleshooting with LED**

### Printing Problems

Problem	Possible Causes	What to Do
Receipt does not come out all the way.	Paper is jammed.	Open the tray and clear any jammed paper.
Printer starts to print, but stops while the receipt is being printed.	Paper is jammed.	Open the tray and clear any jammed paper.
Print is light or spotty.	Paper tickets loaded incorrectly.	Check that the paper is loaded properly.
	Thermal printhead is dirty.	Use recommended thermal receipt paper. Clean printhead at recommended intervals.
Vertical column of print is missing.	Change the paper stack to make sure the thermal coating is not the source. If it does not solve the problem, it could indicate a problem with the printer electronics.	Contact your authorized service representative.
One side or portion of ticket has not been printed	Change the paper stack to make sure the thermal coating is not the source. If it does not solve the problem, it could indicate a problem with the printer electronics.	Contact service representative.

**Table 3: Troubleshooting Printing Problems**

### Printer Does Not Work

Problem	Possible Causes	What to Do
Printer Does Not Function When Turned On.	Printer not plugged in.	Check that printer cables is properly connected on both ends.
		Check that the host or power supply is getting power.
	Tray not fully closed.	Close the tray.
	The power supply voltage is higher than 26.8V.	Adjust the power supply output voltage to 24V +/- 5%.

**Table 4: Printer Does Not Work**

## 2. Media and Supplies Guide

### 2.1 Media Specifications

The printer requires qualified thermal paper with the following specifications:

- 2.1.1 – Ticket dimensions shall be 65mm +/- 1mm (2.56 in +/- .040in) x 156mm +/-1 mm (6.14in +/- 0.040in)
- 2.1.2 – Paper stock shall be furnished in bulk stacks of 200, 400, 600 or 800 tickets.
- 2.1.3 – Tickets shall be attached (chained) to one another at 156mm intervals and supplied in “fan-folded” format
- 2.1.4 – Attachment between tickets shall be made with perforations across the paper width (65mm).
- 2.1.5 – The perforations shall also define the fold point in the paper stock.
- 2.1.6 – Perforation (burst) strength, or pull force, shall be 1.3lbs+/- 0.4 lbs (0.59Kg +/- 0.18 Kg)

### 2.2 Ordering Thermal Paper

We recommend the following paper grade produced by Appleton and Kanzaki Specialty Papers. There is a number of paper converters qualified to supply this paper, provided the stacks are from these recommended grades. We would be happy to provide a quote for qualifying additional grades not listed below.

Manufacturer	Numbers	Nanoptix part no.	Paper Grade
Appleton Papers	Tel:920-991-8438	100505-3024R (200 stack) 100505-3025R (400 stack) 100505-3026R (600 stack) 100505-3027R (800 stack)	Royale 800-4.5
Kanzaki Specialty Papers (USA)	Tel:888-526-9254 Fax: 413-731-8864	100505-3012R (200 stack) 100505-3013R (400 stack) 100505-3014R (600 stack) 100505-3015R (800 stack)	TO-381-N

**Table 5: Ordering Thermal Paper**

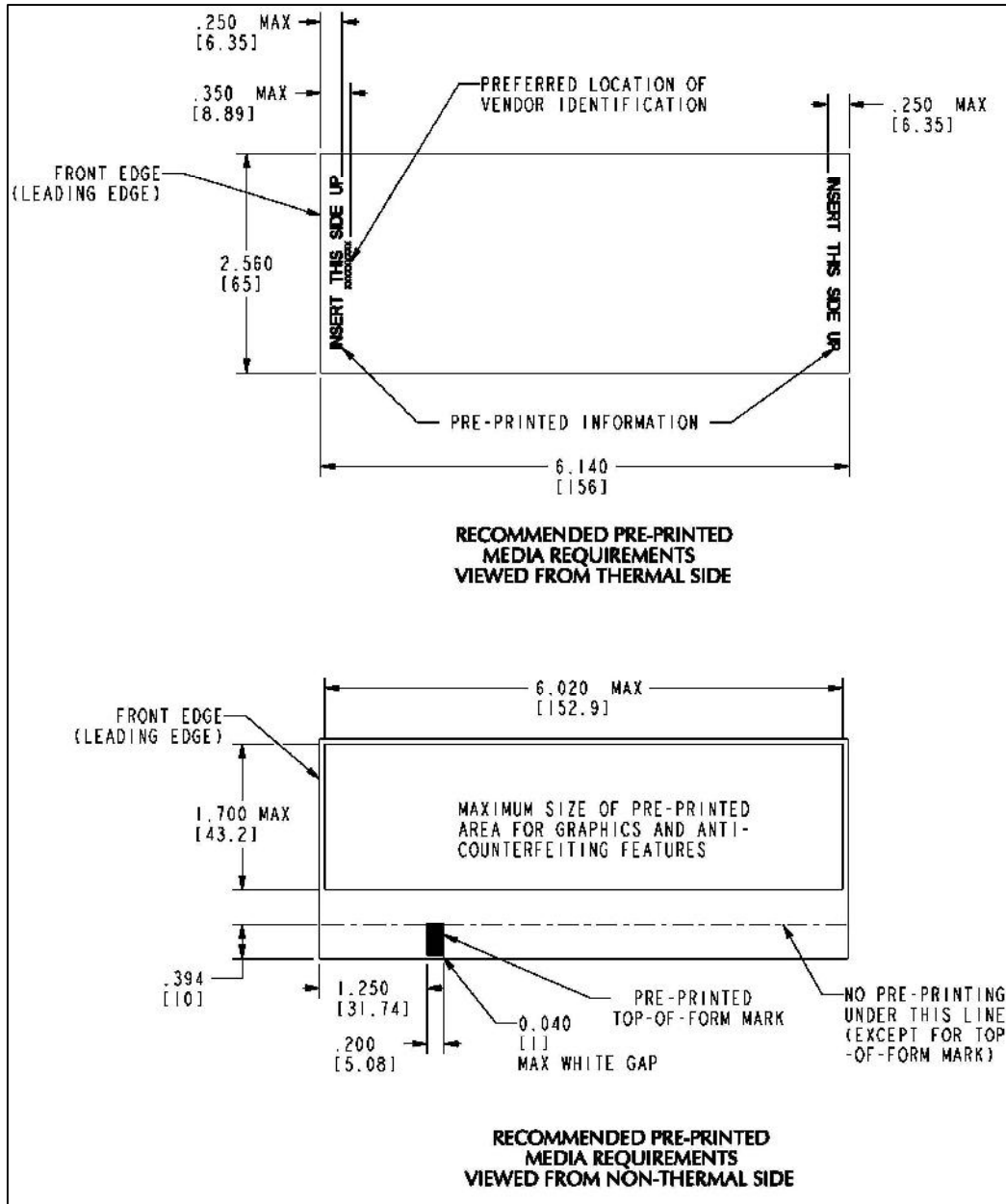
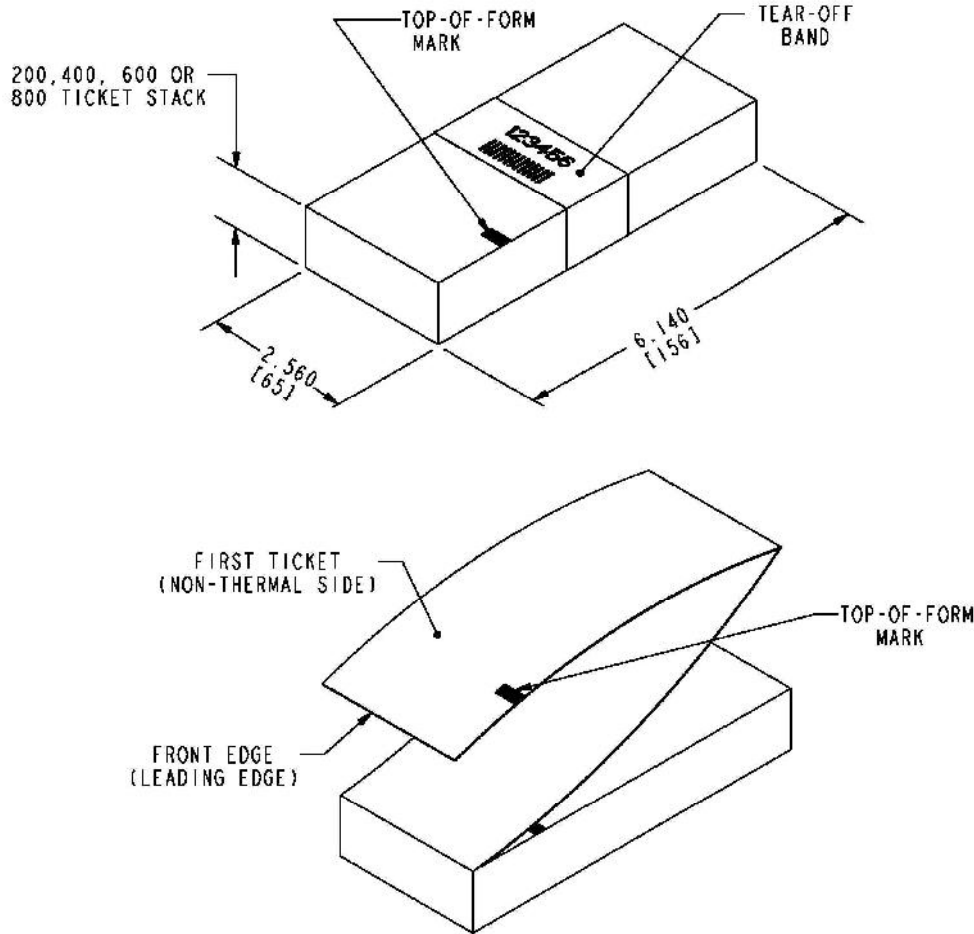

Figure 9: Thermal Paper Specifications



TICKET STACK AND BANDING EXAMPLE



EXAMPLE OF BANDING INFORMATION

Figure 10: Ticket Stack and Banding Example

## 2.3 Ordering Miscellaneous Supplies

### Power Supply and Power Cord

Contact your sales representative to order the power supply listed in the table.

Part	Part Number
14-Pin Molex Power Supply (24VDC, 2.5A max., 60W)	210007-0202R
Power cord (North American)	102080-0000R
Power cord (Continental Europe)	102080-0001R
Power cord (Argentina / Australia)	102080-0003R

**Table 6: Part Numbers**

### Ordering Communication Cables

Contact your sales representative to order the communication cables listed in the table. The numbers are for reference only. Suppliers may use other numbers.

Part	Part Number
RS232 communication cable (14-Pin Molex to DB-9)	210036-0004R
OneCheck In-Line Cable	210036-0003R
USB Cable 2M (A to B)	100390-0001R

**Table 7: Communication Cables Part Numbers**



### Ordering Bezels

Contact your sales representative to order the bezels listed in the table.

<b>Part</b>	<b>Part Number</b>
Bezel Short Green	103663-0000R
Bezel Short Blue	103663-0001R
Bezel Short Red	103663-0008R
Bezel Long Green	103663-0002R
Bezel Long Blue	103663-0003R
Bezel Slanted Green	103663-0004R
Bezel Slanted Blue	103663-0005R
Bezel - External, Blue Illumination (Collect Ticket)	920000-0000R
Bezel - External, Green Illumination (Collect Ticket)	920000-0001R

**Table 8: Bezel Types**

### Ordering Tray Sizes

<b>Part</b>	<b>Part Number</b>
Paycheck 4 - 400 Tray	950020-0001R
Paycheck 4 - 600 Tray	950020-0002R
Paycheck 4 - 800 Tray	950020-0003R

**Table 9: Tray Sizes**

## Communication Cables Pin-Out

The tables below detail the connection pin-out for the Universal Interface (14-pin Molex) on the printer side.

Pin	Signal Name	Printer I/O	Host I/O	Printer Function
1	Reset	Input	Output	Resets Printer
2	PRT_AUX_RXD	Input	Output	Auxiliary Receive
3	V <sub>AUX</sub>	Input	Output	Auxiliary Power
4	PRT_AUX_TXD	Output	Input	Auxiliary Transmit
5	Signal Ground	Signal Ground	Signal Ground	Signal Ground
6	24V	Power Input	n/a	Power Input
7	Power Ground	Power Ground	n/a	Power Ground
8	24V	Power Input	n/a	Power Input
9	Bezel_pwm	24V Output	n/a	Bezel Driver
10	Power Ground	Power Ground	n/a	Power Ground
11	PRT_RS232_RXD	Input	Output	Data Receive
12	PRT_RS232_TXD	Output	Input	Data Transmit
13	PRT_Status	Output	Input	Printer Ready
14	PRT_RS232_RTS	Output	Input	Handshake

**Table 10: 14-Pin Universal Interface Pin-Out**

The tables below detail the connection pin-out for the front Bezel Connector (3-pin Molex).

Pin	Signal	Printer I/O
1	Bezel PWM	Output
2	24VDC	Output
3	GND	GND

**Table 11: Pin-out and signals of Front Molex (for Bezel)**

## APPENDIX A: Mechanical Drawings

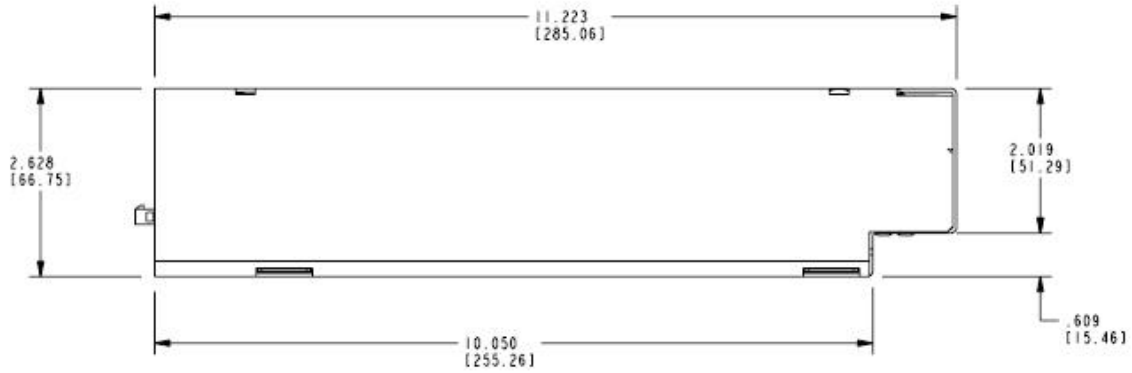

Figure 11: Mechanical Dimensions – Paycheck 4 Printer Right Side View

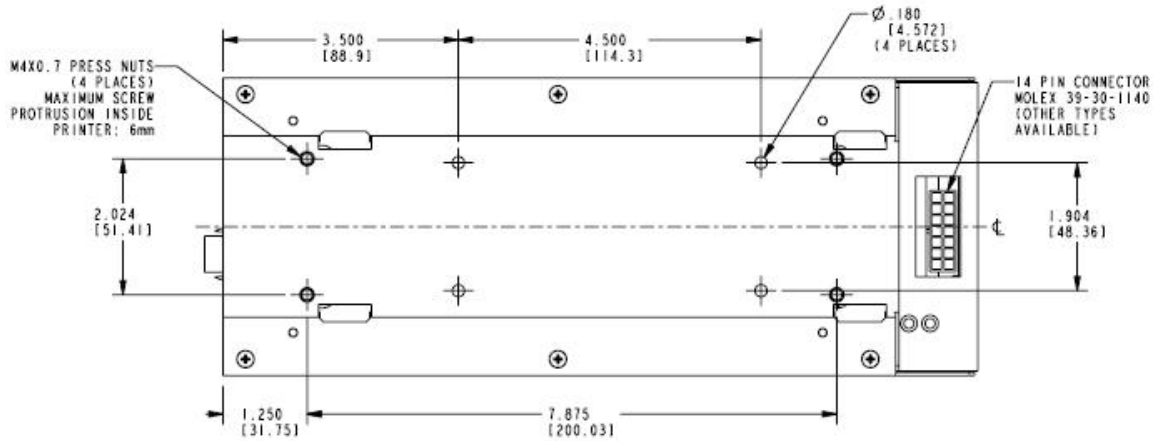

Figure 12: Mechanical Dimensions – Paycheck 4 Printer Bottom View

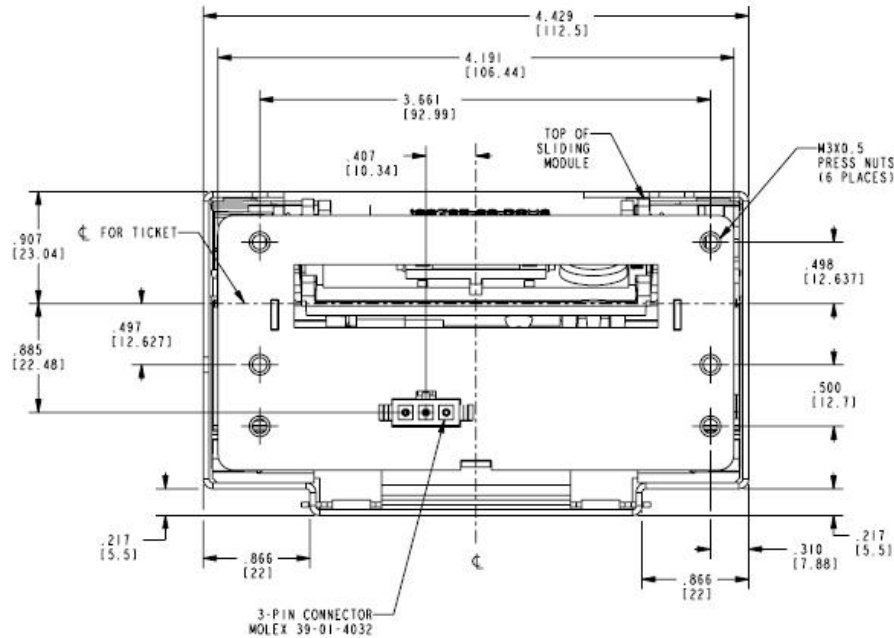

Figure 13: Mechanical Dimensions – Paycheck 4 Printer Front View

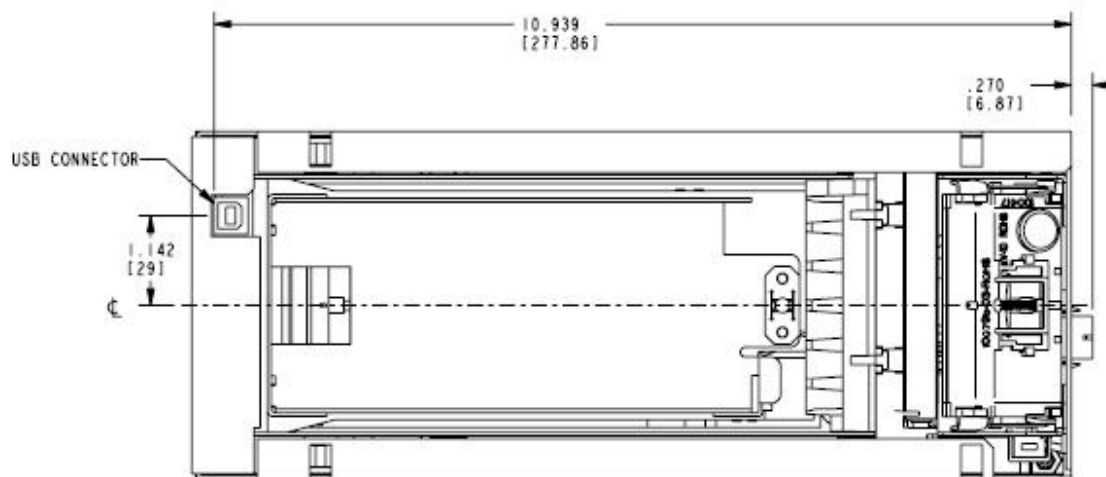

Figure 14: Mechanical Dimensions – Paycheck 4 Printer Top View

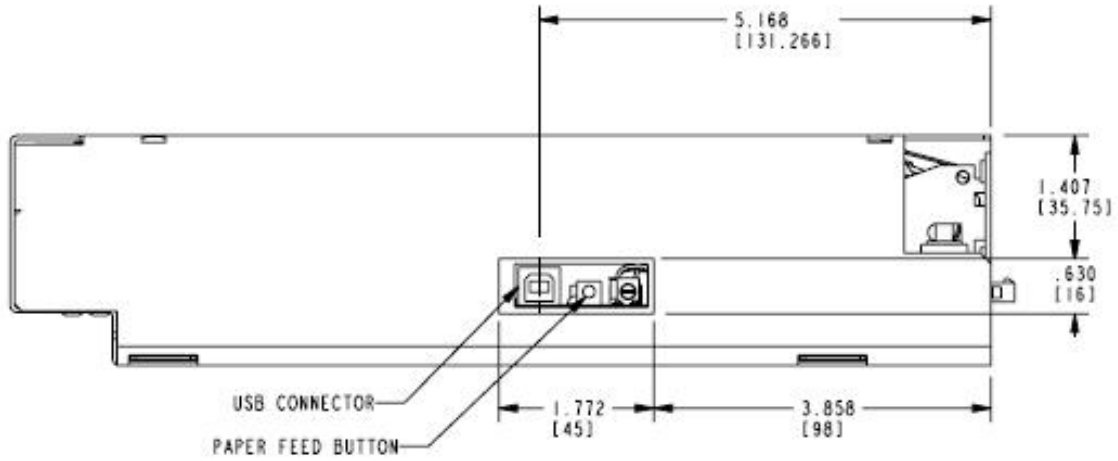

Figure 15: Mechanical Dimensions – Paycheck 4 Printer Left Side View



## **Nanoptix Contact Information**

Nanoptix Inc.  
699 Champlain St.  
Dieppe NB, Canada  
E1A 1P6  
Toll Free (North America): 888-983-3030  
Tel: 506-384-3388  
Fax: 506-384-3588  
E-mail: [info@nanoptix.com](mailto:info@nanoptix.com)  
Web site: [www.nanoptix.com](http://www.nanoptix.com)