

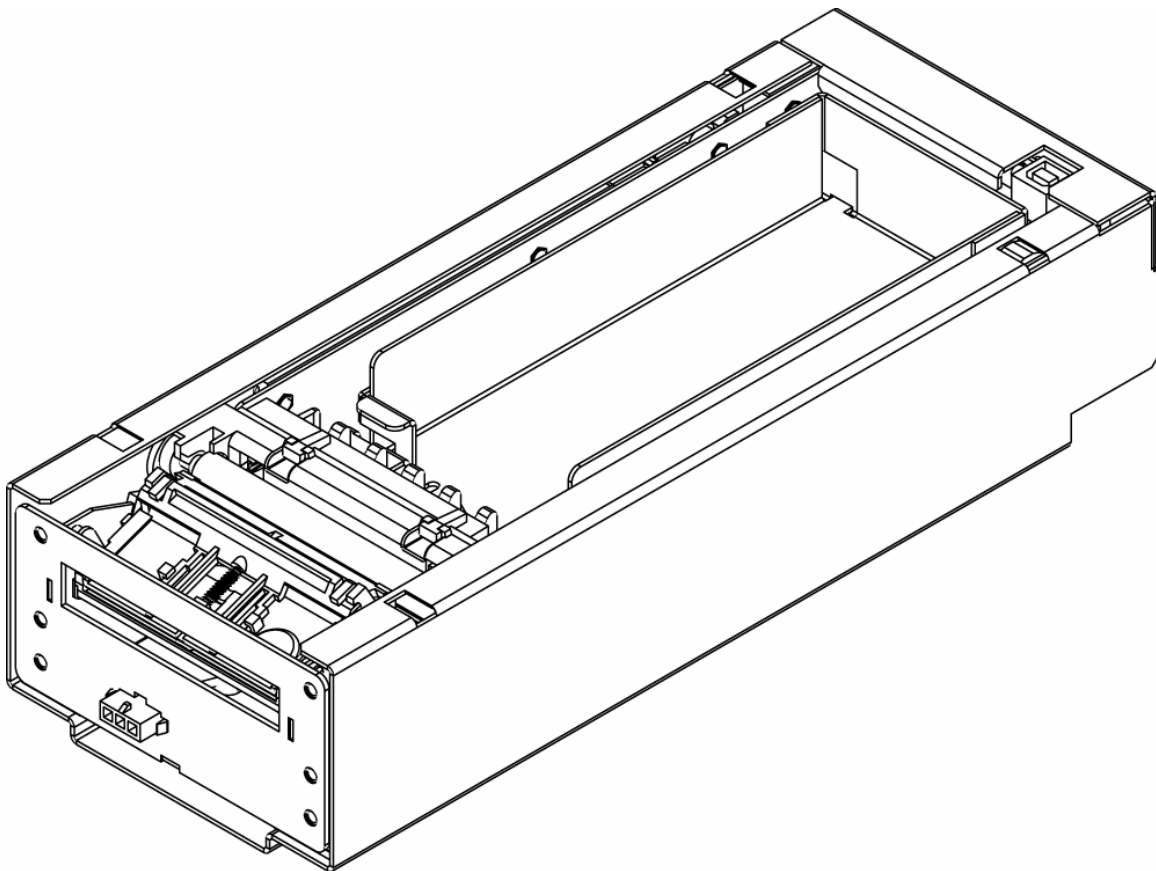

Owner's Manual



First Edition: December 2002
Last Revision: November 2005

Legal Notices

Disclaimer

Information in this document is subject to change without notice. Consult your Nanoptix Inc. sales representative for information that is applicable and current. Nanoptix Inc. reserves the right to improve products as new technology, components, software, and firmware become available.

No part of this document may be reproduced or transmitted in any form or by any means, electronic or mechanical, for any purpose without the express written permission of Nanoptix Inc.

Copyright

Copyright 2003 by Nanoptix Inc.
Dieppe, New Brunswick Canada
All rights reserved
Printed in Canada
Confidential, Unpublished
Property of Nanoptix Inc.

Trademarks

Epson is registered trademark of Epson Corporation.

Windows is registered trademark of Microsoft Corporation.

Nanoptix is a trademark. Other trademarks and registered trademarks are the property of their respective holders.

Federal Communications Commission (FCC) Radio Frequency Interference Statement

Warning

Changes or modifications to this unit not expressly approved by the party responsible for compliance could void the user's authority to operate the equipment.

Note

This equipment has been tested and found to comply with the limits for a Class A digital device, pursuant to Part 15 of the FCC Rules. These limits are designed to provide reasonable protection against harmful interference when the equipment is operated in a commercial environment. This equipment generates, uses, and can radiate radio frequency energy and, if not installed and used in accordance with the instruction manual, may cause harmful interference to radio communications. Operation of this equipment in a residential area is likely to cause harmful interference in which case the user will be required to correct the interference at his own expense.

Information to the User

This equipment must be installed and used in strict accordance with the manufacturer's instructions. However, there is no guarantee that interference to radio communications will not occur in a particular commercial installation. If this equipment does cause interference, which can be determined by turning the equipment off and on, the user is encouraged to contact Nanoptix Inc. immediately.

Nanoptix Inc. is not responsible for any radio or television interference caused by unauthorized modification of this equipment or the substitution or attachment of connecting cables and equipment other than those specified by Nanoptix Inc. The correction of interferences caused by

such unauthorized modification, substitution or attachment will be the responsibility of the user.

In order to ensure compliance with the Product Safety, FCC and CE marking requirements, you must use the power supply, power cord, and interface cable which were shipped with this product or which meet the following parameters:

Power Supply

UL Listed power supply with standard 60Hz-50Hz, 100-240VAC input and 24VDC output equipped with AC line filtering, over-current and short-circuit protection.

Use of this product with a power supply other than the Nanoptix Inc. power supply will require you to test the power supply and Nanoptix Inc. printer for FCC and CE mark certification.

Communication Interface Cable

An approved Nanoptix interface cable must be used with this product. Use of a cable other than Nanoptix approved product will require that you test the cable with the Nanoptix Inc. printer and your system for FCC and CE mark certification.

Power Cord

A UL listed, detachable power cord must be used. A power cord with Type SVT marking must be used. For applications outside the North America, power cords that meet the particular country's certification and application requirements should be used.

Use of a power cord other than described here may result in a violation of safety certifications that is in force in the country of use.

Industry Canada (IC)

Radio Frequency Interference Statement

This Class A digital apparatus meets all requirements of the Canadian Interference-Causing Equipment Regulations.

Cet appareil numérique de la classe A respecte toutes les exigences du Règlement sur le matériel brouilleur du Canada.

Revision History

Date	Changes	Author
22/11/2001	Document Created	Denis Daigle
15/07/2003	Corrections to text	Denis Daigle
15/01/2004	Corrections, added FX chipset option	P.Chiasson
01/03/2005	Added hot swappable option	P.Chiasson
15/11/2005	Revised for Paycheck II	P.Chiasson

Table of Contents

Revision History	iii
1. About the Printer	1
1.1 Description of Printer	1
1.2 General specifications.....	2
1.3 Printer Controls.....	3
Printer Reset (Service use only)	3
Paper Feed Button.....	3
LED	4
1.4 Changing Paper	5
1.5 Testing the Printer	6
1.6 Troubleshooting the Printer.....	7
Troubleshooting with LED.....	7
Printing Problems	7
Printer Does Not Work.....	8
2. Media and Supplies Guide.....	8
2.1 Media Specifications	8
2.2 Ordering Thermal Paper	8
2.3 Ordering Miscellaneous Supplies	11
Power Supply and Power Cord.....	11
Ordering Communication Cables.....	11
Communication Cables Pin-Out	11
APPENDIX A: Mechanical Drawings.....	13

Figures

FIGURE 1: NANOPTIX PAYCHECK PRINTER	1
FIGURE 2: PRINTER RESET	3
FIGURE 3: PAPER FEED BUTTON.....	3
FIGURE 4: LEDS POSITION.....	4
FIGURE 5: LOADING PAPER	5
FIGURE 6: TEST TICKET	6
FIGURE 7: MECHANICAL DIMENSIONS.....	14

Tables

TABLE 1: SPECIFICATION	2
TABLE 2: TROUBLESHOOTING WITH LED.....	7
TABLE 3: TROUBLESHOOTING PRINTING PROBLEMS	7
TABLE 4: PRINTER DOES NOT WORK	8
TABLE 5: ORDERING THERMAL PAPER	8
TABLE 6: PART NUMBERS	11
TABLE 7: COMMUNICATION CABLES PART NUMBERS.....	11
TABLE 8: RS-232 SERIAL INTERFACE PIN-OUT	11
TABLE 9: PINOUT AND SIGNALS OF FRONT MOLEX (FOR BEZEL).....	12

1. About the Printer

1.1 Description of Printer

The Nanoptix Paycheck II Printer, also known as Triton, is extremely fast, quiet, and very reliable. With thermal printing technology, there is no ribbon cassette to change, and paper loading is extremely simple. The printer is small enough to fit almost anywhere and is easy to use with the ticket exiting from the front.

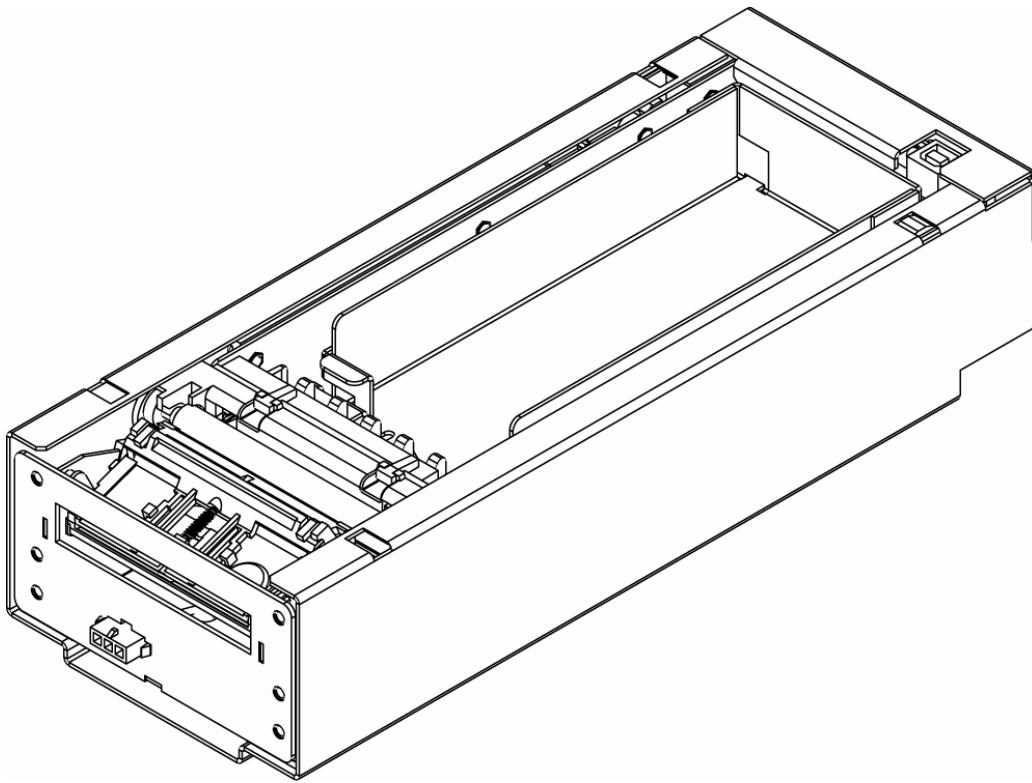

Figure 1: Nanoptix Paycheck Printer

1.2 General specifications

Print Method	Direct Thermal
Resolution	8 dot/mm (203 dpi)
Print Width	64mm
Paper Width	65mm
Cartridge Size	200, 400, 800
Operating Temperature	0 to 50 C
Storage Temperature	-40 C to +65 C
Operating Relative Humidity	5% to 90% RH at 50C (non-condensing)
Communication Interface Options	Serial and USB
Memory/Firmware	1 Mbit of SRAM, 2 Mbit of flash and 16Kbit of EEPROM
Resident Character Sets	Arial Bold (6 sizes) Note: Other Character sets can be programmed quickly
Integrated Bar Codes	UPC-A, UPC-E, interleaved 2 of 5, 3 of 9, Code 128, EAN 8, EAN 13. Note: Other Bar Codes can be programmed quickly
Speed	Up to 125 mm/second
Sensors	<ul style="list-style-type: none"> • Paper in • Tray open • Top of form • Paper low
Human Interface	Drop-in paper loading, status LED, paper feed button
Dimensions	113mm width x 67mm height x 286mm depth
Weight	2.3 Kg
Immunity	EN 55024 Information Technology Equipment
Emission Standards	United States - FCC Part 15 Subpart A Canada - Industry Canada ICES-003 Europe – EN 55022 Class A emissions Information Technology Equipment

Table 1: Specification

1.3 Printer Controls

Printer Reset (Service use only)

To reset the printer, simply unplug and plug the cable. Once plugged in, the printer goes through a startup routine and resets itself.

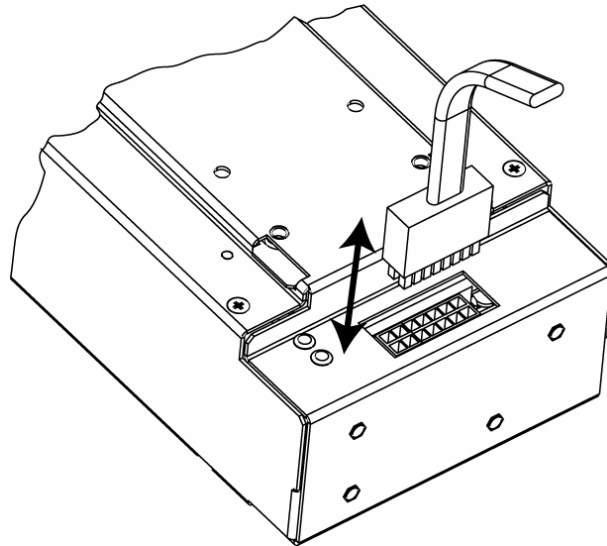

Figure 2: Printer Reset

Paper Feed Button

Use the Paper Feed Button to advance the paper. The paper will automatically feed. Tear off the form that has been fed and the printer will be ready to print on a full form.

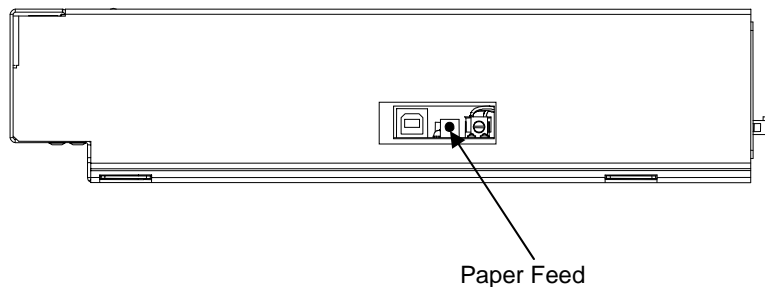

Figure 3: Paper Feed Button

LED

The LED on the main controller board shows the printer status. Please refer to section 1.7 for LED status and troubleshooting with LED. An external LED can be connected through the front 3-pin Molex connector. The pin-out is described in section 2.3.

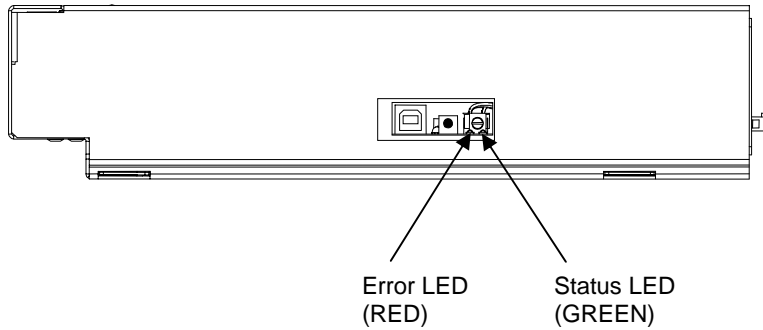

Figure 4: LEDs position

1.4 Changing Paper

Change the paper when the paper is low or out.

Caution: Do not operate the printer or host computer if the printer runs out of paper. The printer will not operate without paper, but it may continue to accept data from the host computer. Because the printer cannot print any transactions, the data may be lost.

Load a stack of tickets into the printer. The maximum stack that will fit in the ticket cartridge is 200, 400 or 800 tickets depending on the cartridge option that was purchased with your printer.

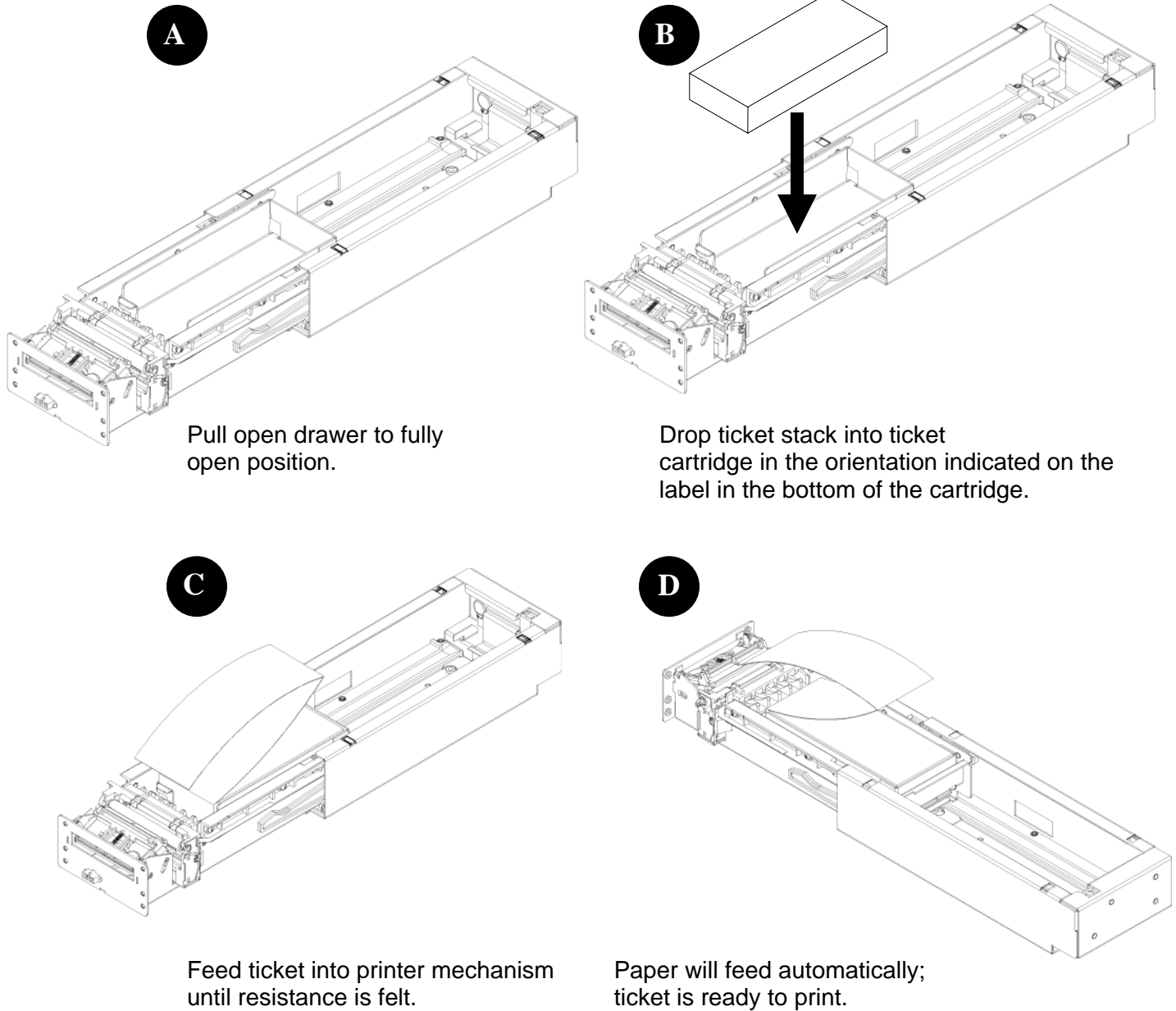

Figure 5: Loading Paper

1.5 Testing the Printer

Run this test to check the printer. The test prints and cuts a resident test ticket. Verify this ticket to judge the printing quality.

```
Model: TRITON-1
Firmware: TRT-2.4 1 J-61AU
COMMUNICATION
Interface: Serial
Baud: 19200
Data Bits: 8
Parity: NONE
Handshaking: NONE
Print mode: NTM
Aux Port: Disabled
PRINT CONTROL
Darkness Control: -15%
Voltage: 23.9 Volts
Temperature: 21 Celcius
Speed: 4.0 IPS
Black Bar Index: Right
SYSTEM RESOURCES
FLASH -Used: 48110
-Free: 17425
LIBRARY INVENTORY
Templates:
0,1,2,3,4,5,6,7,8,9,A,B
Print Regions:
1,2,3,4,5,6,7,8,h,9,A,B,C,D,E,F,G,I,J,K,L,N,O,P,Q,R,
S,T,U,Z,X,a,b,c,d,e,f,g,i,j,k,l,m,n,o,p,q,
Graphics: None
Fonts: 0,2,3,4,5,7,8,15
MANUFACTURING INFORMATION
Printer ID: N000024
Date Code: 07D20B14
PWM Setting: 7F7F7F7FFFFFFF
A to D: DE7AA400FD000000
Status: C21-2.41G-40-40-40-40-P
```

Figure 6: Test Ticket

To print the test ticket, power-on the printer while pressing and holding the Paper Feed Button for approximately 3 seconds. A test ticket similar to above will be printed approximately 5 seconds after. Press the paper feed button once more and the ticket will feed. Pressing the button again will result in blank tickets.

1.6 Troubleshooting the Printer

The printer is simple and generally trouble-free, but from time to time problems may occur. Follow these procedures to determine the cause and resolution of any problems the printer may be having. If the procedures in this section do not correct the problem, contact a service representative.

Troubleshooting with LED

Status LED (red)	Error LED (green)	Condition
OFF	ON	Paper Out
OFF	MED BLINK	Temperature Error
OFF	SLOW BLINK	Voltage Error
ON	FAST BLINK	Print Head Error
ON	FAST BLINK	Missing Black Index Mark
ON	FAST BLINK	Paper Jam

Table 2: Troubleshooting with LED

Printing Problems

Problem	Possible Causes	What to Do
Receipt does not come out all the way.	Paper is jammed.	Open the tray and clear any jammed paper.
Printer starts to print, but stops while the receipt is being printed.	Paper is jammed.	Open the tray and clear any jammed paper.
Print is light or spotty.	Paper tickets loaded incorrectly.	Check that the paper is loaded properly.
	Thermal printhead is dirty.	Use recommended thermal receipt paper. Clean printhead at recommended intervals.
Vertical column of print is missing.	Change the paper stack to make sure the thermal coating is not the source. If it does not solve the problem, it could indicate a problem with the printer electronics.	Contact your authorized service representative.
One side or portion of ticket has not been printed	Change the paper stack to make sure the thermal coating is not the source. If it does not solve the problem, it could indicate a problem with the printer electronics.	Contact service representative.

Table 3: Troubleshooting Printing Problems

Printer Does Not Work

Problem	Possible Causes	What to Do
Printer Does Not Function When Turned On.	Printer not plugged in.	Check that printer cables is properly connected on both ends.
	Tray not fully closed.	Check that the host or power supply is getting power. Close the tray.

Table 4: Printer Does Not Work

2. Media and Supplies Guide

2.1 Media Specifications

The printer requires qualified thermal paper with the following specifications:

2.1.1 – Ticket dimensions shall be 65+/- 1mm (2.56 in +/- .040”) x 156 +/-1 mm (6.14 +/- 0.040”)

2.1.2 – Paper stock shall be furnished in bulk stacks of 200, 400, 600 or 800 tickets.

2.1.3 – Tickets shall be attached (chained) to one another at 156mm intervals and supplied in “fan-folded” format

2.1.4 – Attachment between tickets shall be made with perforations across the paper width (65mm).

2.1.5 – The perforations shall also define the fold point in the paper stock.

2.1.6 – Perforation (burst) strength, or pull force, shall be 1.3+/- 0.4 lbs (0.59 +/-0.18 Kg)

2.2 Ordering Thermal Paper

We recommend the following paper grade produced by Appleton and Kanzaki Specialty Papers. There are a number of paper converters qualified to supply this paper, provided the stacks are from these recommended grades.

Manufacturer	Numbers	Nanoptix part no	Paper Grade
Appleton Papers	Tel:920-991-8438	100505-3024 (200 stack) 100505-3025 (400 stack) 100505-3026 (600 stack) 100505-3027 (800 stack)	Royale 700-4.5
Kanzaki Specialty Papers (USA)	Tel:888-526-9254 Fax: 413-731-8864	100505-3012 (200 stack) 100505-3013 (400 stack) 100505-3014 (600 stack) 100505-3015 (800 stack)	TO-381-N

Table 5: Ordering Thermal Paper

We would be happy to provide a quote for qualifying additional grades not listed above.

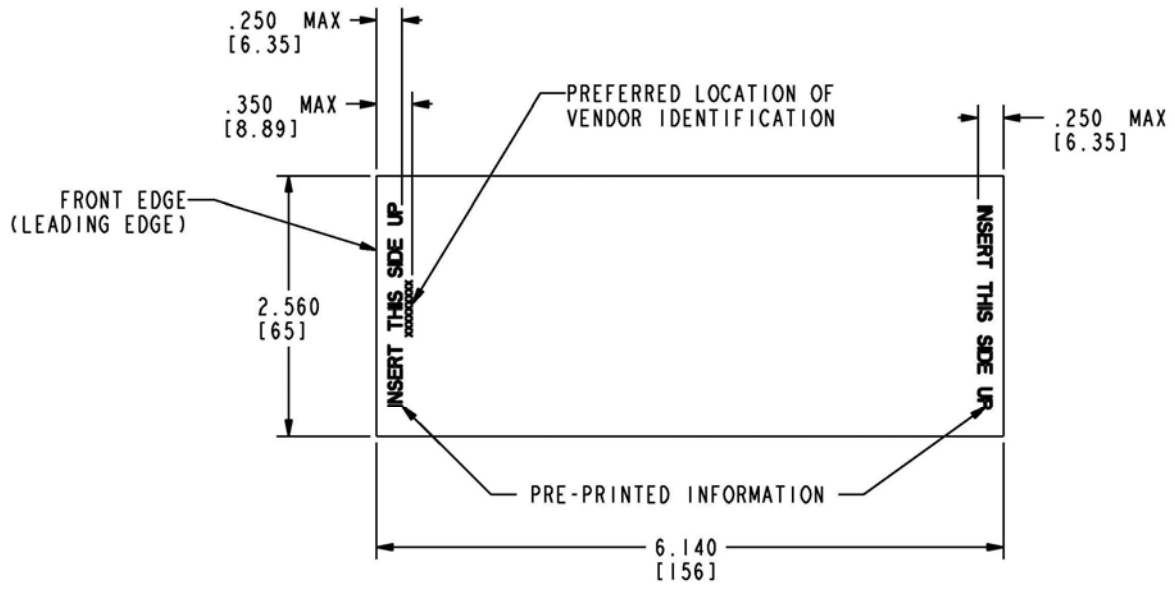

RECOMMENDED PRE-PRINTED MEDIA REQUIREMENTS VIEWED FROM THERMAL SIDE

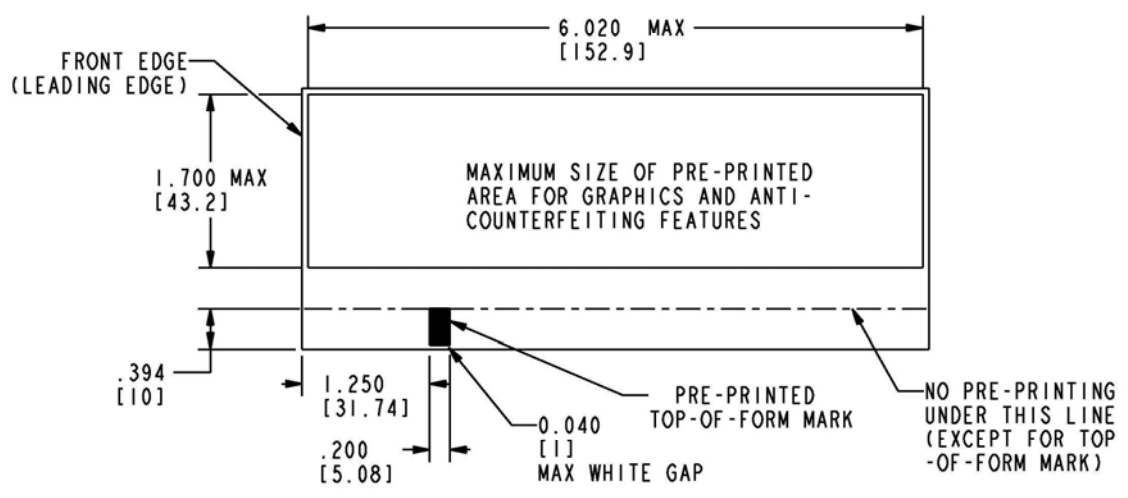

RECOMMENDED PRE-PRINTED MEDIA REQUIREMENTS VIEWED FROM NON-THERMAL SIDE

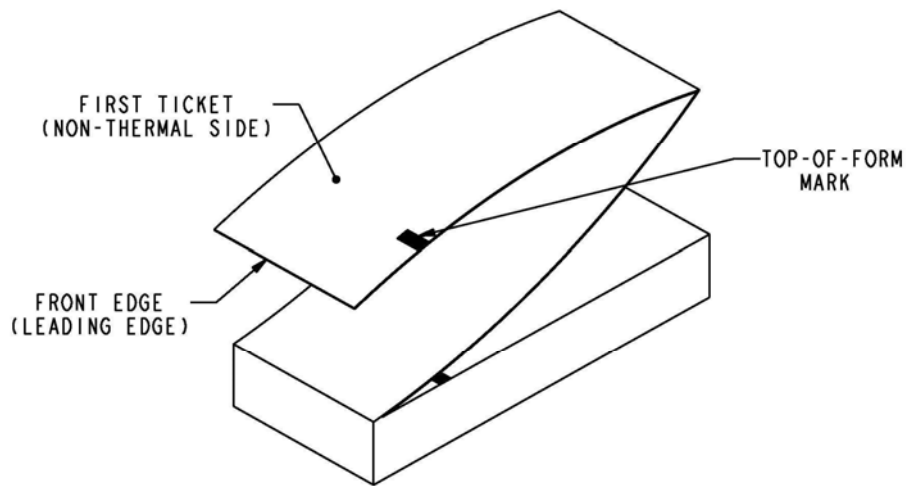
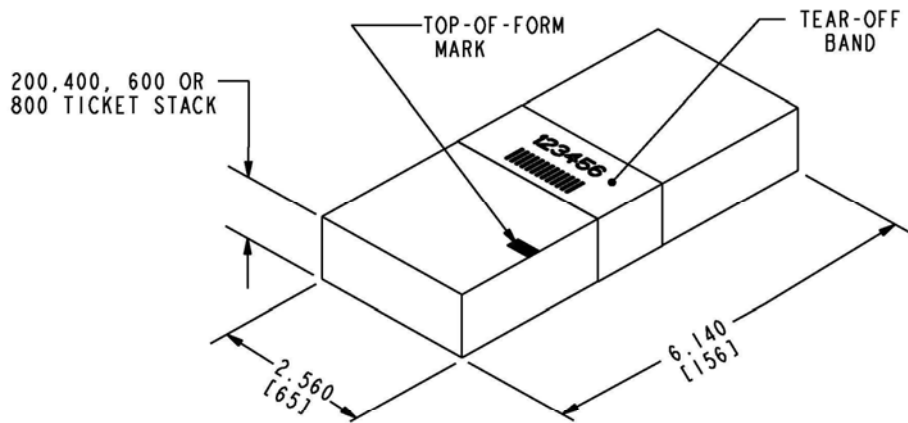

TICKET STACK AND BANDING EXAMPLE



EXAMPLE OF BANDING INFORMATION

2.3 Ordering Miscellaneous Supplies

Power Supply and Power Cord

Contact your sales representative to order the power supply listed in the table.

Part	Part Number
Power Supply (24VDC, 2.5A max., 60W)	100600-0001
Power cord (North American)	102080-0013
Power cord (continental Europe)	102080-0014

Table 6: Part Numbers

Ordering Communication Cables

Contact your sales representative to order the communication cables listed in the table. The numbers are for reference only. Suppliers may use other numbers.

Part	Part Number
RS232 communication cable (12 pin Molex to DB-9)	101101-00

Table 7: Communication Cables Part Numbers

Communication Cables Pin-Out

The tables below detail the connection pin-out for the Serial interface (12-pin Molex) on the printer side.

Pin	Signal Name	Printer I/O	Host I/O	Printer Function
1	24V	Power Input	n/a	Power Input
2	PRT_RS232_TXD	Output	Input	Data transmit
3	PRT_RS232_RXD	Input	Output	Data receive
4	n/a	No connect	n/a	None
5	Signal Ground	Signal Ground	Signal Ground	Signal Ground
6	RS232_DSR	4K7 pull up to 24V	Input	Printer Ready
7	n/a	No connect	n/a	none
8	PRT_RS232_RTS (host CTS)	Output	Input	Handshake
9	Bezel_pwm	24V Output	n/a	Bezel driver
10	Signal Ground	Signal Ground	Signal Ground	Signal Ground
11	Signal Ground	Signal Ground	Signal Ground	Signal Ground
12	24V	Power Input	n/a	Power Input
Shell	Frame Ground	Frame Ground	Frame Ground	Shield

Table 8: RS-232 Serial Interface Pin-Out

The tables below detail the connection pin-out for the front Bezel Connector (3-pin Molex).

Pin	Signal	Printer I/O
1	Bezel PWM	Output
2	24VDC	Output
3	GND	GND

Table 9: Pinout and signals of Front Molex (for Bezel)

APPENDIX A: Mechanical Drawings

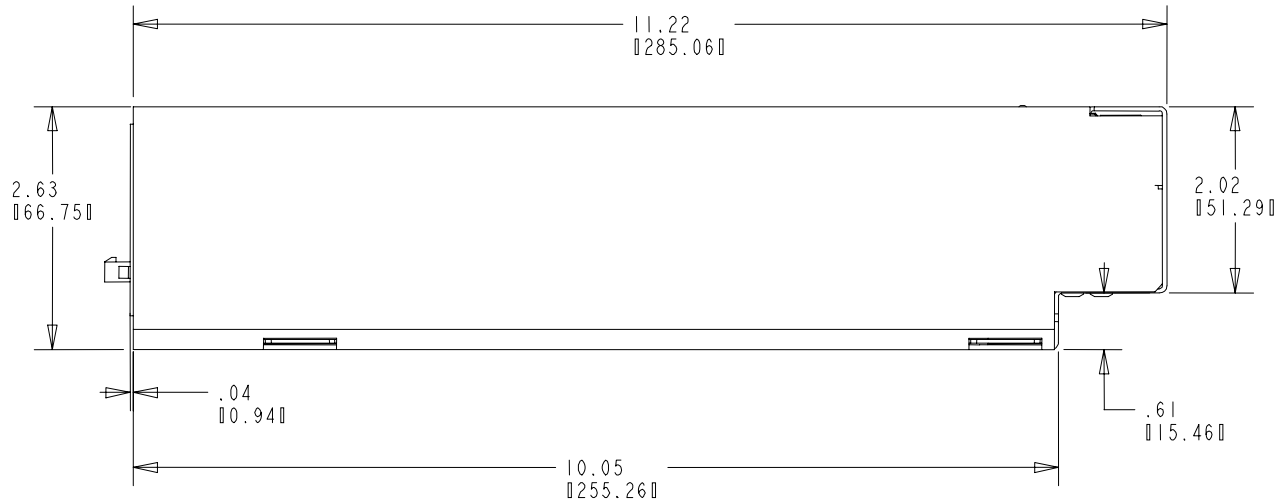

Side View

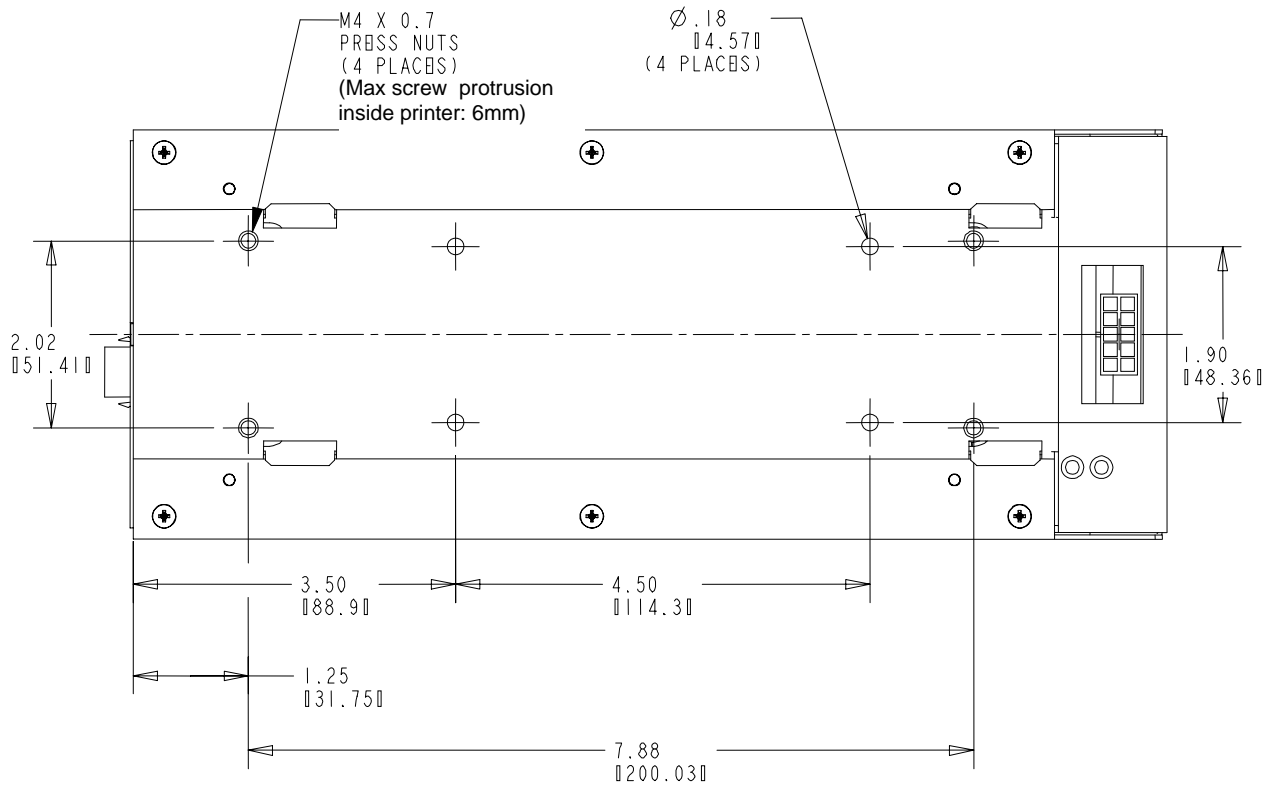

Bottom View

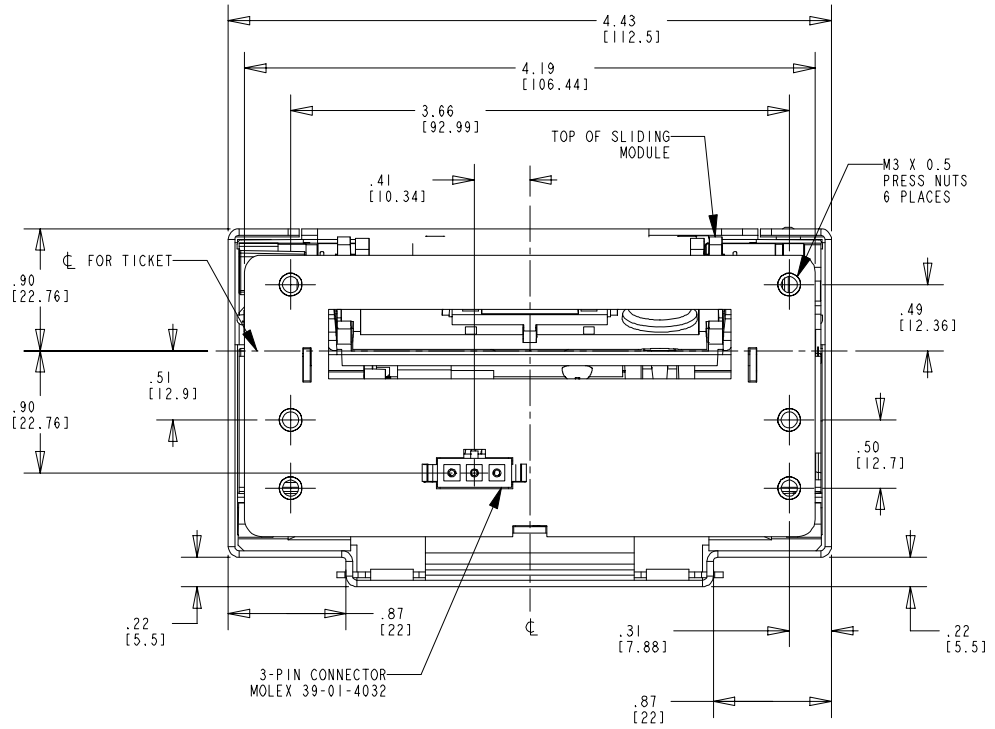

Front View

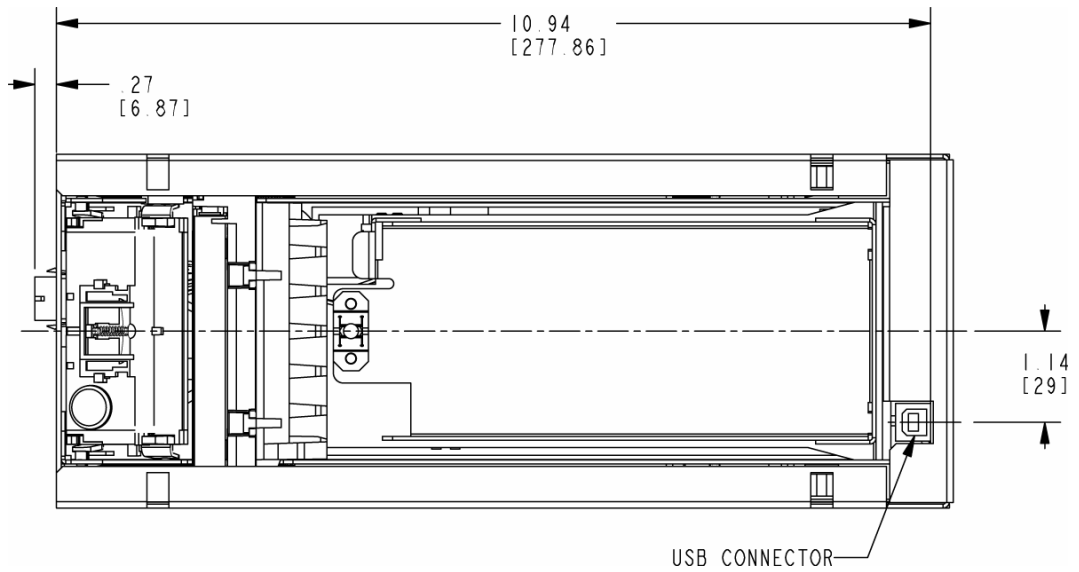

Top View

Figure 7: Mechanical Dimensions