

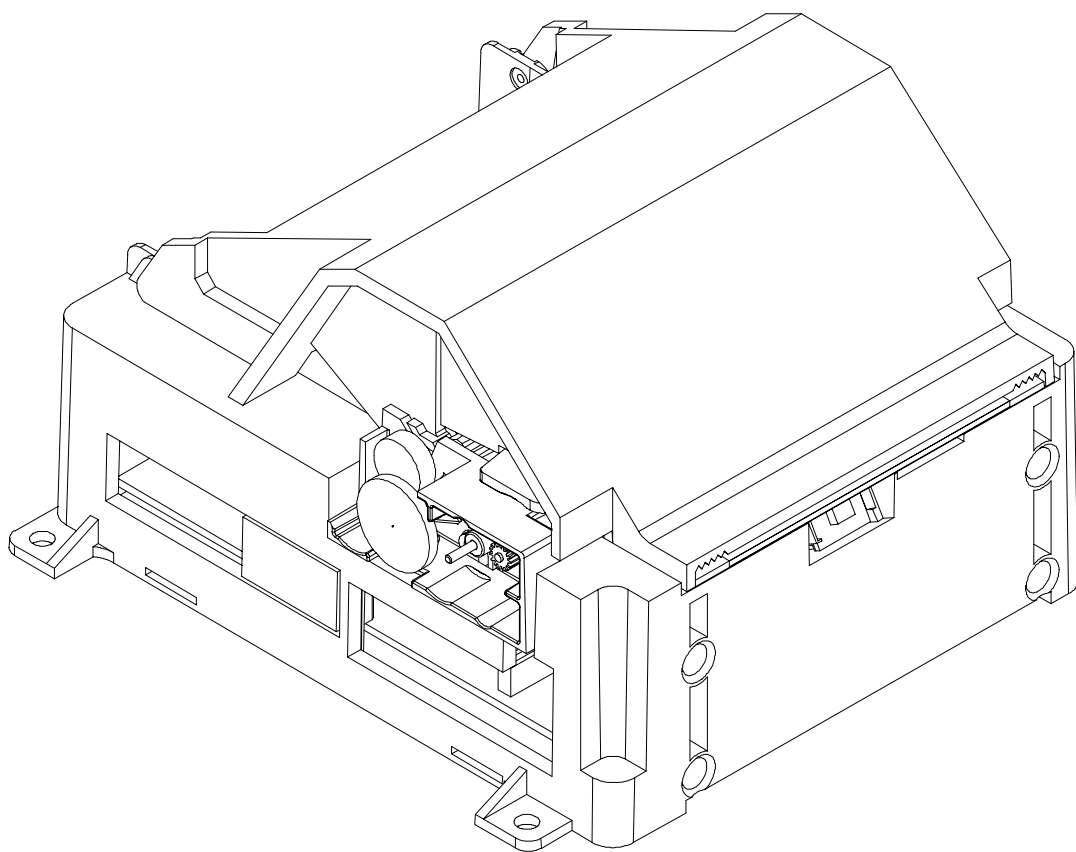

EZ-Tear Thermal Printer

Owner's Manual



First Edition: July 2004
Last Revision: July, 2005

Document #102136



Legal Notices

Disclaimer

Information in this document is subject to change without notice. Consult your Nanoptix Inc. sales representative for information that is applicable and current. Nanoptix Inc. reserves the right to improve products as new technology, components, software, and firmware become available.

No part of this document may be reproduced or transmitted in any form or by any means, electronic or mechanical, for any purpose without the express written permission of Nanoptix Inc.

Copyright

Copyright 2004 by Nanoptix Inc.
Dieppe, New Brunswick Canada
All rights reserved
Printed in Canada
Confidential, Unpublished
Property of Nanoptix Inc.

Trademarks

Epson is registered trademark of Epson Corporation.

Windows is registered trademark of Microsoft Corporation.

Nanoptix is a trademark. Other trademarks and registered trademarks are the property of their respective holders.

Federal Communications Commission (FCC) Radio Frequency Interference Statement

Warning

Changes or modifications to this unit not expressly approved by the party responsible for compliance could void the user's authority to operate the equipment.

Note

This equipment has been tested and found to comply with the limits for a Class B digital device, pursuant to Part 15 of the FCC Rules. These limits are designed to provide reasonable protection against harmful interference when the equipment is operated in a commercial environment. This equipment generates, uses, and can radiate radio frequency energy and, if not installed and used in accordance with the instruction manual, may cause harmful interference to radio communications. Operation of this equipment in a residential area is likely to cause harmful interference in which case the user will be required to correct the interference at his own expense.

Information to the User

This equipment must be installed and used in strict accordance with the manufacturer's instructions. However, there is no guarantee that interference to radio communications will not occur in a particular commercial installation. If this equipment does cause interference, which can be determined by turning the equipment off and on, the user is encouraged to contact Nanoptix Inc. immediately.



Nanoptix Inc. is not responsible for any radio or television interference caused by unauthorized modification of this equipment or the substitution or attachment of connecting cables and equipment other than those specified by Nanoptix Inc. The correction of interferences caused by such unauthorized modification, substitution or attachment will be the responsibility of the user.

In order to ensure compliance with the Product Safety, ICES, FCC and CE marking requirements, you must use the power supply, power cord, and interface cable which were shipped with this product or which meet the following parameters:

Power Supply

UL Listed power supply with standard 60Hz-50Hz, 100-240VAC input and 24VDC output equipped with AC line filtering, over-current and short-circuit protection.

Use of this product with a power supply other than the Nanoptix Inc. power supply will require you to test the power supply and Nanoptix Inc. printer for FCC and CE mark certification.

Communication Interface Cable

An approved Nanoptix interface cable must be used with this product. Using a cable other than Nanoptix approved product will require that you test the cable with the Nanoptix Inc. printer and your system for FCC and CE mark certification.

Power Cord

A UL listed, detachable power cord must be used. A power cord with Type SVT marking must be used. For applications outside the North America, power cords that meet the particular country's certification and application requirements should be used.

Use of a power cord other than described here may result in a violation of safety certifications that is in force in the country of use.

Industry Canada (IC)

Radio Frequency Interference Statement

This Class A digital apparatus meets all requirements of the Canadian Interference-Causing Equipment Regulations.

Cet appareil numérique de la classe A respecte toutes les exigences du Règlement sur le matériel brouilleur du Canada.



Table of Contents

1.	About the Printer	1
1.1	Description of Printer	1
1.2	Models Available.....	2
	Connector Orientation.....	2
1.3	General specifications.....	3
1.4	Installation	4
	Mounting your printer	4
1.5	Printer Controls.....	4
	To reset Printer	4
	Paper Feed Button.....	5
1.6	Changing Paper	6
1.7	Testing the Printer	8
1.8	Troubleshooting the Printer.....	9
	Printer LED	9
	Printing Problems	9
	Printer Does Not Work.....	10
2.	Media and Supplies Guide.....	10
2.1	Thermal Paper Specifications.....	10
2.2	Ordering Thermal Paper	10
2.3	Ordering Miscellaneous Supplies	11
	Power Supply and Power Cord.....	11
	Ordering Communication Cables.....	11
	Communication Cables Pin-Out	12
3.	Communicating with the Printer	13
	APPENDIX A: Mechanical Drawings.....	14



Figures

FIGURE 1: NANOPTIX EZ-TEAR PRINTER	1
FIGURE 2: NANOPTIX EZ-TEAR CONNECTION	2
FIGURE 3: RESETTING PRINTER.....	4
FIGURE 4: PAPER FEED BUTTON.....	5
FIGURE 5: LOADING PAPER.....	6
FIGURE 6: TEST TICKET	8



Tables

TABLE 1: SPECIFICATION	3
TABLE 2: TROUBLESHOOTING WITH THE STATUS LED.....	9
TABLE 3: TROUBLESHOOTING PRINTING PROBLEMS	9
TABLE 4: PRINTER DOES NOT WORK	10
TABLE 5: THERMAL PAPER DIMENSIONS	10
TABLE 6: ORDERING THERMAL PAPER	10
TABLE 7: POWER SUPPLY AND POWER CORD PART NUMBERS	11
TABLE 8: COMMUNICATION CABLES PART NUMBERS.....	11
TABLE 9: RS-232 INTERFACE PIN-OUT	12

1. About the Printer

1.1 Description of Printer

The Nanoptix EZ-Tear thermal printers are extremely fast, quiet, and very reliable. With thermal printing technology, there is no ribbon cassette to change, and paper loading is extremely simple. The printer is small enough to fit almost anywhere and is easy to use with the ticket exiting from the front.

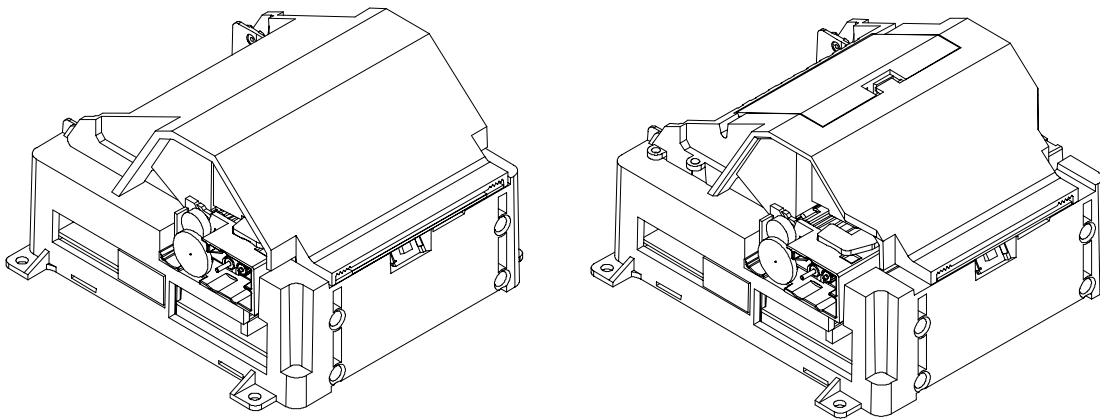

Figure 1: Nanoptix EZ-Tear-80 Printer (left), Nanoptix EZ-Tear-65 Printer (right)

1.2 Models Available

There are several models of Nanoptix EZ-Tear printers available. Options include: paper width, top of form, paper low, communication interface, left or right side and spindle bucket. Please contact your representative for the most up-to-date options available.

Connector Orientation

When installing your printer, please ensure that the connections and controls are accessible during operation. The EZ-Tear printers can be ordered with the connectors and controls on either the right or the left hand side of the printer.

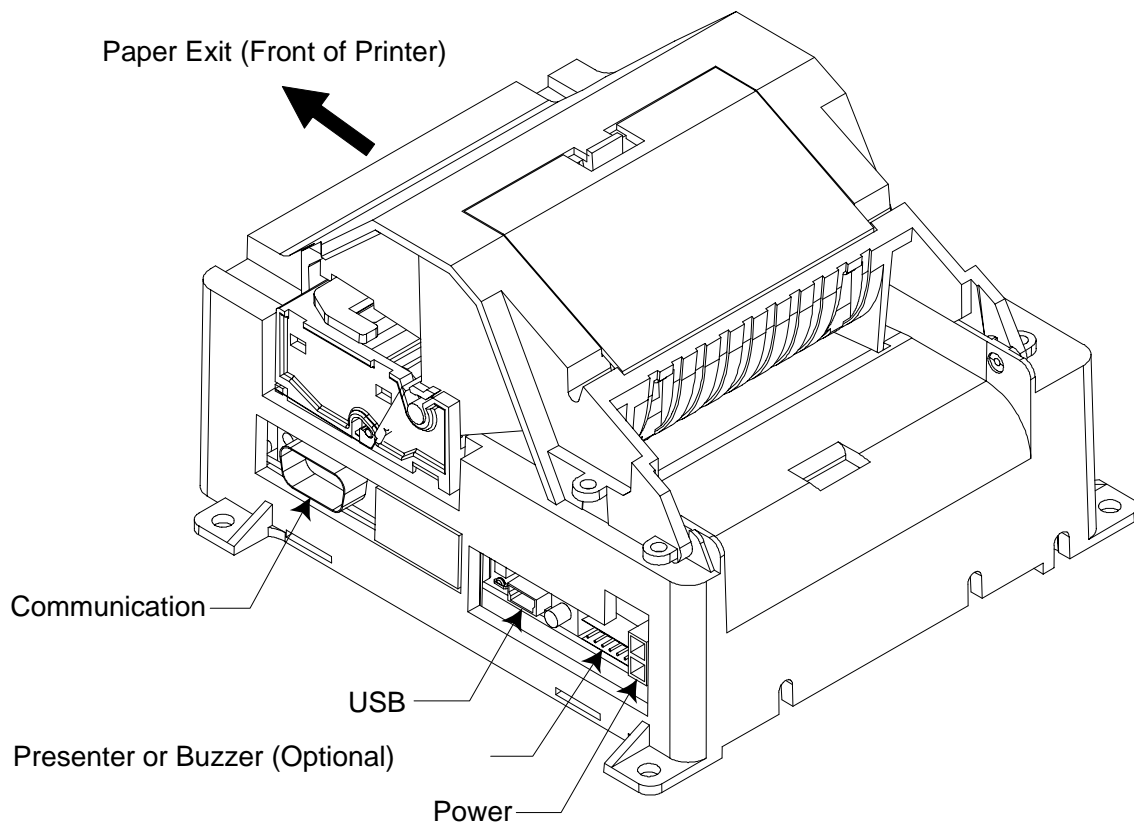

**Figure 2: Nanoptix EZ-Tear connection
(with connectors pictured on the Right side)**



1.3 General specifications

Print Method	Direct Thermal
Resolution	8 dot/mm (203 dpi)
Print Width	80mm
Paper Width	80mm or 65 mm
Max Roll Diameter	6" (152.4mm) on spindle, 4" (101.6mm) in bucket
Operating Temperature	0 to 50 C
Storage Temperature	-40 C to +65 C
Operating Relative Humidity	5% to 90% RH at 50C (non-condensing)
Communication Interface Options	USB, RS-232C, RS-485, IEEE1284
Optional Interface	None
Memory/Firmware	1 Mbit of SRAM, 4 Mbit of flash and 128Kbit of EEPROM
Resident Character Sets	Arial Bold (6 sizes) Note: Other Character sets can be programmed quickly
Integrated Bar Codes	UPC-A, UPC-E, interleaved 2 of 5, 3 of 9, Code 128, EAN 8, EAN 13. Note: Other Bar Codes can be programmed quickly
Speed	Up to 130 mm/second
Sensors	<ul style="list-style-type: none"> • Paper out • Door open • Top of form (optional) • Paper low (optional)
Human Interface	Status LED, paper feed button
Dimensions	131mm width x 82mm height x 133.5mm depth
Weight	0.55 Kg
Emission Standards	United States - FCC Part 15 Subpart B Canada - Industry Canada ICES-003 Europe – EN 55022 Class A emissions
Immunity Standards	EN55024

Table 1: Specification

1.4 Installation

Mounting your printer

The Nanoptix EZTear printers have four 4.5mm mounting holes at the base that can be used to mount the printer on a variety of surfaces. Please refer to the drawings in Figure 8 for proper hole spacing.

Note: The Nanoptix EZTear printers must be mounted on surfaces with a flatness of less than 0.63mm (.025") total deviation. If the mounting surface in your application does not meet the above specification (ex. shop grade plywood), please contact Nanoptix for options that will ensure the proper functioning of your EZTear printer.

1.5 Printer Controls

To reset Printer

Simply plug and unplug the printer to reset in the event of a fault condition. Once the Printer is re-plugged, it will go through a startup routine and resets itself. The LED will light up. Note: there should be paper loaded in the printer and the door should be closed.

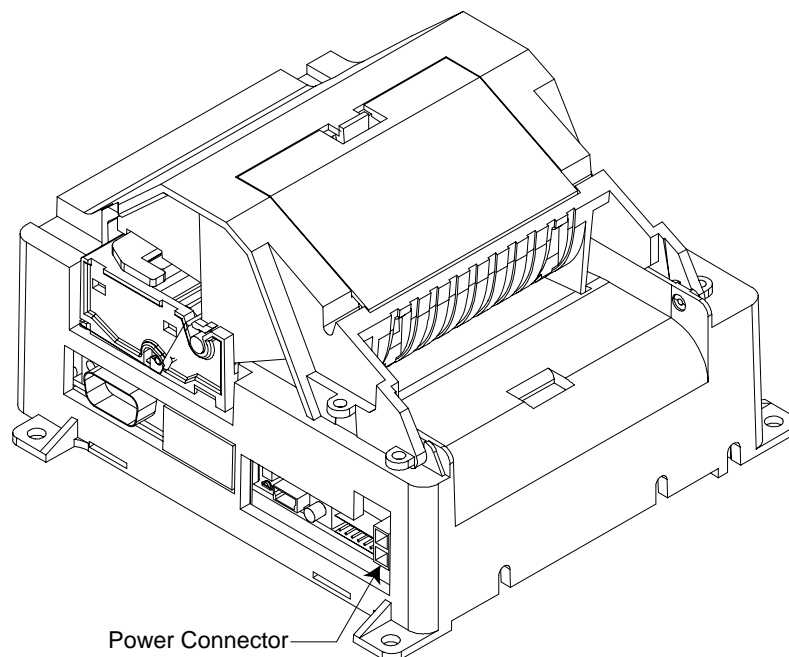

Figure 3: Resetting Printer

Paper Feed Button

Use the Paper Feed Button to advance the paper.

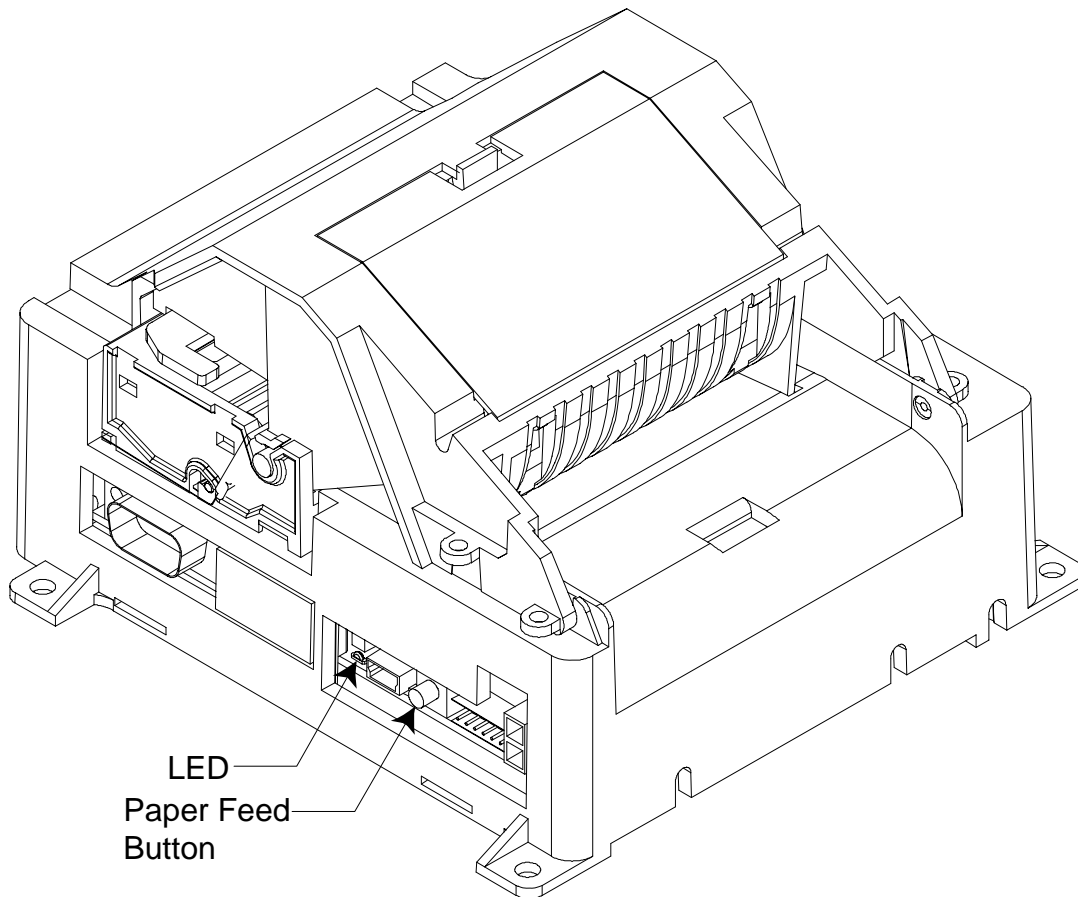

Figure 4: Paper Feed Button

1.6 Changing Paper

Caution: Do not operate the printer if it runs out of paper. The printer will not operate without paper, but it may continue to accept data from the host computer. Because the printer cannot print any transactions, the data may be lost.

1. Open the top cover by pulling under the tab on both sides.
2. Remove the used roll.
3. Tear off the end of the new roll so that the edge is loose and place the new roll into the spindle bracket with a few inches of loose paper at the bottom of the roll.

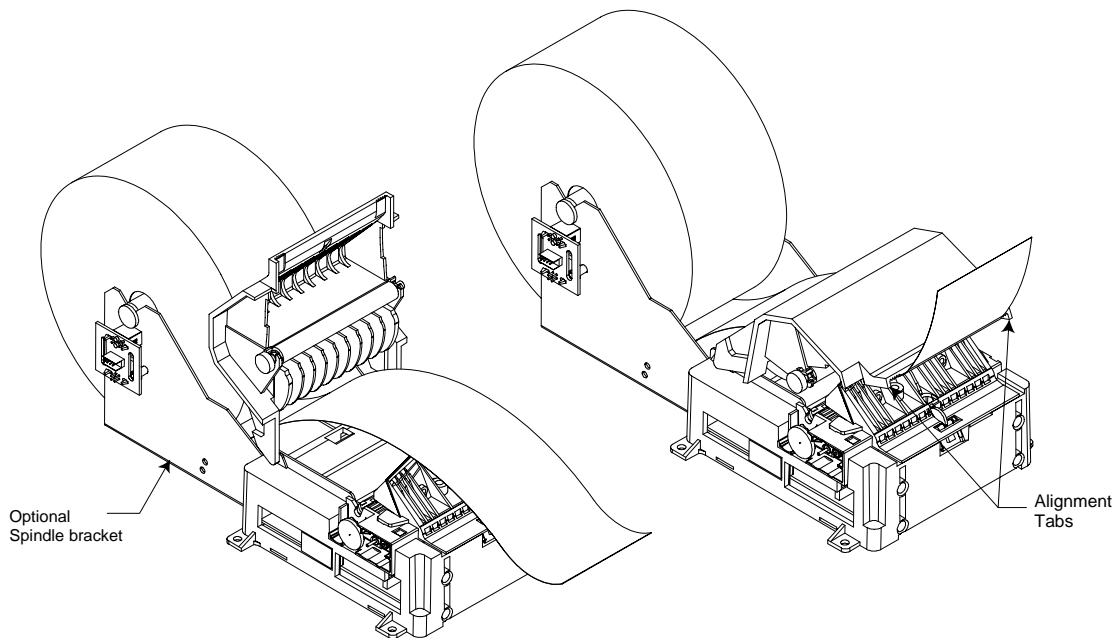

Figure 5: Loading Paper

Caution: The tear blade has sharp corners and caution should be exercised when loading paper not to cause personal injury.

Notice: Be sure the paper unrolls from the bottom. Otherwise, the printer will not Print.



4. Pull up on the bottom of the paper roll and align the paper properly before closing the cover.

5. Advance the paper by pressing on the paper feed button and tear off the excess paper.

Note: In the event of a paper jam, remove the roll, tear a new clean edge, and replace it in the paper bucket, as described above. Be sure that the paper unrolls from the bottom of the roll.

1.7 Testing the Printer

Run this test to check the printer. The test prints a resident test ticket. Verify this ticket to judge the printing quality. This is an example, the printer's actual status and associated printout will vary depending upon the configuration shipped to you.

Model:	EZ tear
Firmware:	T13-XXXXXXXXXX
COMMUNICATION	
Interface:	IEEE1284 (0) or Serial
Baud:	9600
Data Bits:	8
Parity:	NONE
Handshaking:	NONE
Print Mode:	NTL
Aux Port:	Disabled
PRINT CONTROL	
Darkness Control:	-1%
Voltage:	24.2 Volts
Temperature:	26 Celcius
Speed:	4 IPS
Black Bar Index:	Disabled
SYSTEM RESOURCES	
FLASH	-Used: 0
	-Free: 24576
LIBRARY INVENTORY	
Templates:	0,1,2
Print Regions:	1,2,3,4,5,6,7,8, h,9,A,B,C,D,E,F,G, I,J,K,L,N,O,P,Q,R, S,T,U,Z,X,a,b,c,d, e,f,g,i,j,k,l,m,n, o,p,q,
Graphics:	None
Fonts:	0,3,5,7,8
MANUFACTURING INFORMATION	
Printer ID:	5465789
Date Code:	20184
PWM Setting:	7F7F7F7FFFFFFF
A to D:	DE7AA400FD000000
Resets:	9
Tickets:	00001336
Status:	T13-XXXX- 0-40-40-40-P

Figure 6: Test Ticket

To print the test ticket, power-on the printer while pressing and holding the Paper Feed Button for approximately 6 seconds. A test ticket similar to above will be printed approximately 5 seconds after. Press the paper feed button once more and the ticket will feed. Pressing the button again will result in blank tickets.



1.8 Troubleshooting the Printer

The printer is simple and generally trouble-free, but from time to time minor problems may occur. Follow these procedures to determine the cause and resolution of any problems the printer may be having. If the procedures in this section do not correct the problem, contact a service representative. (1-888-983-3030 ext. 213)

Printer LED

Condition	LED Status
Unit ready	ON
Unit is in Reset or Booting	OFF
Unit in standby (powered off)	OFF
Paper Out	Slow Blink
Door Open	Fast Blink
Paper Jam	Fast Blink
Missing Black Index Mark	Fast Blink
Temperature Error	Med Blink
Voltage Error	Med Blink
Print Head Error	Med Blink

Table 2: Troubleshooting with the status LED

Printing Problems

Problem	Possible Causes	What to Do
Receipt does not come out all the way.	Paper is jammed.	Open the top cover, inspect and clear any jammed paper.
Printer starts to print, but stops while the receipt is being printed.	Paper is jammed.	Open the receipt cover, inspect and clear any jammed paper.
Print is light or spotty.	Paper roll loaded incorrectly.	Check that the paper is loaded properly.
	Thermal printhead is dirty.	Use recommended thermal receipt paper. Clean the Print Head with Nanoptix authorized cleaner.
Vertical column of print is missing.	This indicates a serious problem with the printer electronics.	Contact your authorized service representative.
One side of receipt is missing.	This indicates a serious problem with the printer electronics.	Contact your authorized service representative.

Table 3: Troubleshooting Printing Problems

Printer Does Not Work

Problem	Possible Causes	What to Do
Printer Does Not Function When Turned On.	Printer not plugged in.	Check that printer cables are properly connected on both ends. Check that the host or power supply is switched on. Check Printer LED.
	Door not fully Closed or paper not loaded.	Close the door and load paper.

Table 4: Printer Does Not Work

2. Media and Supplies Guide

2.1 Thermal Paper Specifications

The printer requires qualified thermal paper with the following dimensions:

Width	Diameter
80 mm \pm .2 mm (3.15 in. \pm .008 in.) or 65mm \pm .2 mm (2.60 in. \pm .008 in.)	152.4 mm max. (6 in.) when using spindle, 101.6mm max (4 in.) when using bucket

Table 5: Thermal Paper Dimensions

The paper must not be attached to the core. If Top of Form Option is installed, paper with a black stripe (20% max reflectance) at the end of the roll can be used to indicate that the paper is running low.

2.2 Ordering Thermal Paper

We recommend the following paper grades. There are a number of paper converters qualified to supply this paper, provided the rolls are from these recommended grades. Contact a Nanoptix sales representative if more information is required.

Manufacturer	Numbers	Paper Grade
Kanzaki Specialty Papers (USA)	Tel: 888-526-9254 Fax: 413-731-8864	P-310 (Standard Sensitivity) P-350 (High Sensitivity)

Table 6: Ordering Thermal Paper



2.3 Ordering Miscellaneous Supplies

Power Supply and Power Cord

Contact your sales representative to order the power supply and power cords listed in the table. The numbers are for reference only. Suppliers may use other numbers.

Part	Part Number
Power Supply (24VDC, 2.5A max., 60W)	100600-0004
Power Cord - North America	102080
Power Cord - Continental Europe	102086

Table 7: Power Supply and Power Cord Part Numbers

Ordering Communication Cables

Contact your sales representative to order the communication cables listed in the table. These are Nanoptix part numbers. Suppliers may use other numbers.

Part Description	Part Number
RS232 communication cable (DB-9 male plug to DB-25 female receptacle)	102107
Standard RS232 communication cable (DB-9 male plug to DB-9 female receptacle)	102082
Parallel communication cable (IEEE 1284 Type C to A – Mini-Centronics to DB25)	102084
USB communication cable (Type mini B to A)	102085

Table 8: Communication Cables Part Numbers



Communication Cables Pin-Out

The tables below detail the connection pin-out for the RS-232 interface (Female Receptacle DB-9).

Pin	Signal Name	Printer I/O	Host I/O	Printer Function
1	n/a	51R pull up to 5V	Input	Aux Power (low current)
2	PRT_RS232_TXD	Output	Input	Data transmit
3	PRT_RS232_RXD	Input	Output	Data receive
4	n/a	No connect	Output	None
5	Signal Ground	Signal Ground	Signal Ground	Signal Ground
6	RS232_DSR	Output	Input	Printer Ready/ Fault
7	PRT_RS232_CTS (host RTS)	Input	Output	Handshake
8	PRT_RS232_RTS (host CTS)	Output	Input	Handshake
9	n/a	100k pull up to 5V	Input	None
Shell	Frame Ground	Frame Ground	Frame Ground	Shield

Table 9: RS-232 Interface Pin-Out

3. Communicating with the Printer

Over the years, Nanoptix has developed emulations for compatibility with the most popular printers in the market. At the time of printing this manual, the following emulations are available:

- Epson 570 (for use with Windows™ XP or 2000 driver)
- Epson TM-T88III
- Star TUP-400
- Axiohm A722
- Ithaca P70
- Ithaca P170
- Citizen 3551

Please contact your sales representative if you require other emulations. If we do not have the emulation you need, we can provide most emulations in a short timeframe. If you are not required to emulate other printer, please ask your sales representative for the latest Nanoptix Windows Driver or the "Nanoptix Programming Guide" which will list the Nanoptix ESC/P commands.

APPENDIX A: Mechanical Drawings

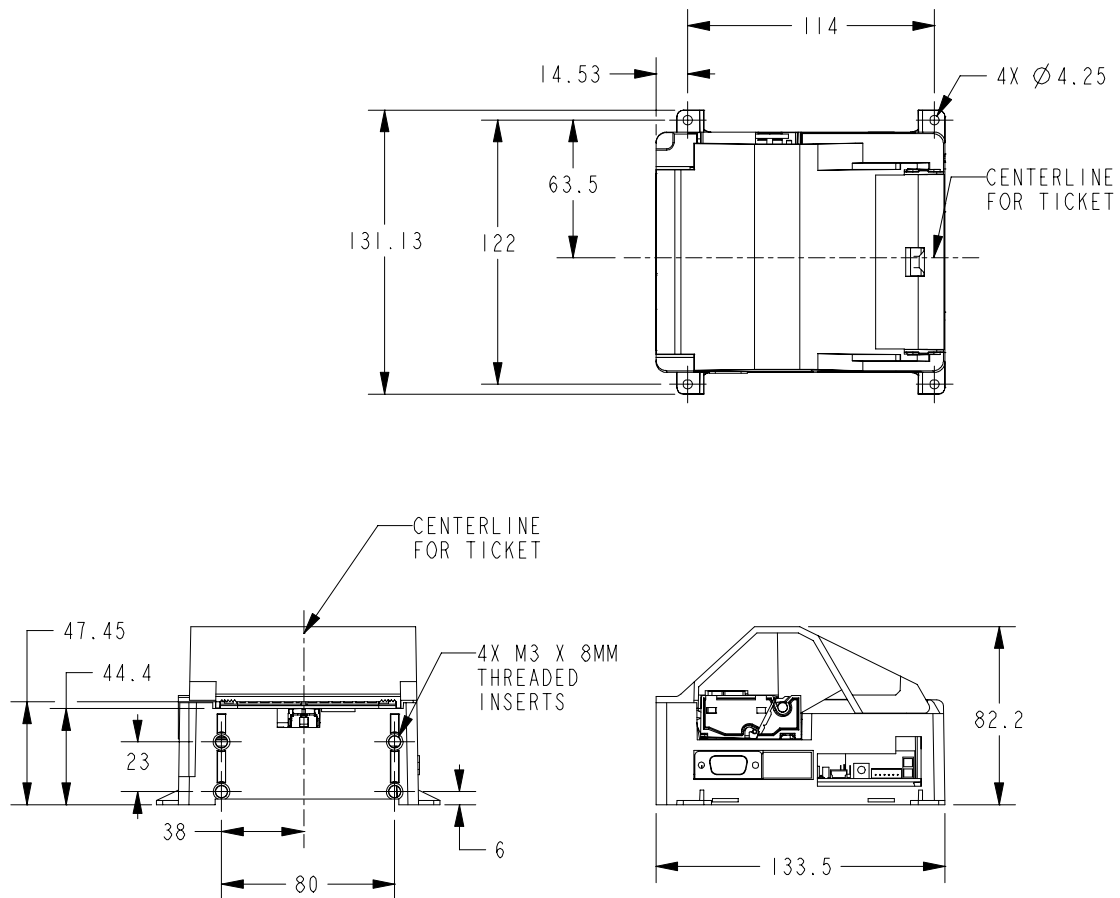

Figure 8: Mechanical Dimensions
(All dimensions in millimeters, tolerance +/-0.25mm)

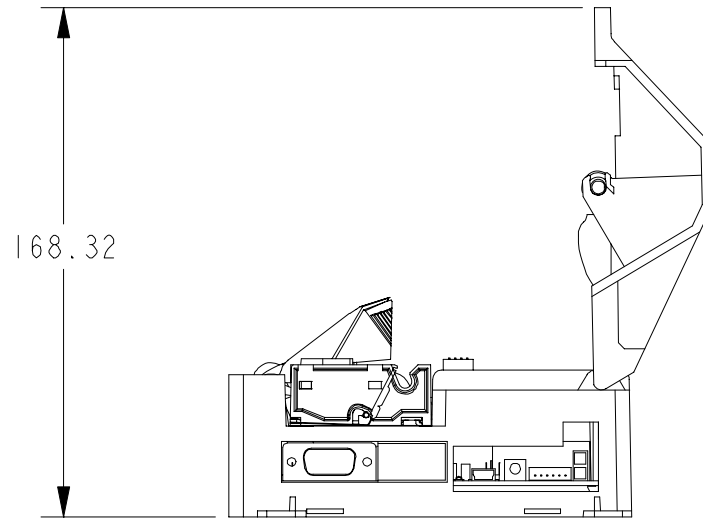

Figure 9: Mechanical Dimensions (Clearance for Cover)
(All dimensions in millimeters, tolerance +/-0.25mm)