

Compliance test report ID

188614-2TRFEMC

Date of issue

November 7, 2011

EN 55024: 2010

Information technology equipment —

— Immunity characteristics — Limits and methods of measurement

Applicant **Nanoptix Inc**
Product **HSVL Thermal Printer**
Model **HSVL™**

Nemko Canada Inc., a testing laboratory, is accredited by the Standards Council of Canada. The tests included in this report are within the scope of this accreditation



Test location

Nemko Canada Inc.
303 River Road
Ottawa, ON, K1V 1H2
Canada

Telephone +1 613 737 9680
Facsimile +1 613 737 9691
Toll free +1 800 563 6336
Website www.nemko.com

Tested by Daniel Hynes, Senior EMC Specialist

Reviewed by



Andrey Adelberg, Senior EMC/Wireless Specialist

November 7, 2011

Date

Limits of responsibility

Note that the results contained in this report relate only to the items tested and were obtained in the period between the date of initial receipt of samples and the date of issue of the report.

This test report has been completed in accordance with the requirements of ISO/IEC 17025. All results contain in this report are within Nemko Canada's ISO/IEC 17025 accreditation.

Copyright notification

Nemko Canada Inc. authorizes the applicant to reproduce this report provided it is reproduced in its entirety and for use by the company's employees only. Any use which a third party makes of this report, or any reliance on or decisions to be made based on it, are the responsibility of such third parties.

Nemko Canada Inc. accepts no responsibility for damages, if any, suffered by any third party as a result of decisions made or actions based on this report.

© Nemko Canada Inc.



Table of Contents

Table of Contents	3
Section 1 Report summary	4
1.1 Test specifications	4
1.2 Statement of compliance	4
1.3 Exclusions.....	4
1.4 Test report revision history	4
Section 2 Summary of test results	5
2.1 Results	5
Section 3 Equipment under test (EUT) details	7
3.1 Applicant	7
3.2 Sample information	7
3.3 EUT information	7
3.4 EUT exercise and monitoring details	7
3.5 EUT setup details	8
Section 4 Engineering considerations.....	9
4.1 Modifications incorporated in the EUT	9
4.2 Technical judgment.....	9
4.3 Deviations from laboratory tests procedures	9
Section 5 Test conditions	10
5.1 Atmospheric conditions.....	10
5.2 Power supply range	10
Section 6 Measurement uncertainty	11
6.1 Uncertainty of measurement.....	11
Section 7 Terms and definitions.....	12
7.1 Performance terms and definitions	12
Section 8 Testing data.....	13
8.1 Radio-frequency electromagnetic field amplitude modulated	13
8.2 Radio-frequency continuous conducted	16
8.3 Electrostatic discharge.....	18
8.4 Surge	23
8.5 Fast transients	25
8.6 Voltage dips and voltage interruptions.....	27
Section 9 EUT photos.....	29
9.1 External photos	29

Section 1 Report summary

1.1 Test specifications

EN 55024: 2010

Information technology equipment — Immunity characteristics — Limits and methods of measurement

1.2 Statement of compliance

In the configuration tested, the EUT was found compliant.

Testing was completed against all relevant requirements of the test standard. Results obtained indicate that the product under test complies in full with the requirements tested. The test results relate only to the items tested.

See *“Summary of test results”* for full details.

1.3 Exclusions

None

1.4 Test report revision history

None

Section 2 Summary of test results

2.1 Results

Table 2.1-1: Enclosure results

Environmental phenomenon	Test specification	Units	Performance criteria	Basic standard	Verdict
Power-frequency magnetic field	50 1	Hz A/M (r.m.s)	A	EN 61000-4-8	Not applicable
Radio-frequency electromagnetic field amplitude modulated	80–1000 3 80	MHz V/m (unmodulated r.m.s) % AM (1kHz)	A	EN 61000-4-3	Pass
Electrostatic discharge (ESD)	4 (Contact discharge) 8 (Air discharge)	kV (charge voltage) kV (charge voltage)	B	EN 61000-4-2	Pass
Notes: EUT does not contain any magnetically sensitive devices.					

Table 2.1-2: Signal ports and telecommunication ports

Environmental phenomenon	Test specification	Units	Performance criteria	Basic standard	Verdict
Radio-frequency continuous conducted	0.15–80 3 80	MHz V (unmodulated r.m.s) % AM (1kHz)	A	EN 61000-4-6	Pass
Surge (line to ground)	10/700 1	Tr/Th μ s kV (peak)	C	EN 61000-4-5	Not applicable
	10/700 1	Tr/Th μ s kV (peak)	C		
Fast transients	0.5 5/50 5	kV (peak) Tr/Th ns Repetition rate kHz	B	EN 61000-4-4	Pass
Notes: The EUT does not contain ports that connect directly to outdoor cables.					

Table 2.1-3: Input DC power port (excluding equipment marketed with an a.c/d.c. power converter)

Environmental phenomenon	Test specification	Units	Performance criteria	Basic standard	Verdict
Radio-frequency continuous conducted	0.15–80 3 80	MHz V (unmodulated r.m.s) % AM (1kHz)	A	EN 61000-4-6	Not applicable
Surge (line to ground)	1.2/50 (8/20) 0.5	Tr/Th μ s kV (peak)	B	EN 61000-4-5	Not applicable
Fast transients	0.5 5/50 5	kV (peak) Tr/Th ns Repetition rate kHz	B	EN 61000-4-4	Not applicable
Notes: EUT does not contain a DC port.					

2.1 Results, continued

Table 2.1-4: Input AC power ports (including equipment marketed with a separate a.c./d.c power converter)

Environmental phenomenon	Test specification	Units	Performance criteria	Basic standard	Verdict
Radio-frequency continuous conducted	0.15–80 3 80	MHz V (unmodulated r.m.s) % AM (1kHz)	A	EN 61000-4-6	Pass
Voltage dip	100 0.5	% reduction period	B	EN 61000-4-11	Pass
	30 25	% reduction periods	C		
Voltage interruptions	100 250	% reduction periods	C	EN 61000-4-11	Pass
Surge	1.2/50 (8/20) 1 (line to line) 2 (line to ground)	Tr/Th μ s kV (peak) kV (peak)	B	EN 61000-4-5	Pass
Fast transients	1	kV (peak)	B	EN 61000-4-4	Pass
	5/50 5	Tr/Th ns Repetition rate kHz			

Section 3 Equipment under test (EUT) details

3.1 Applicant

Company name	Nanoptix Inc
Company address	699 Champlain St Dieppe, NB E1A 1P6

3.2 Sample information

Receipt date	October 27, 2011
Nemko sample ID number	Item # 1

3.3 EUT information

Product name	HSV L Thermal Printer
Model	HSV L™
Serial number	VL00160
Part number	950100
Power requirements	24 V _{DC} , 2.4 A
Manufacturer	Nanoptix Inc 699 Champlain St Dieppe, NB E1A 1P6

Product description and theory of operation

Thermal printer. To put the paper, power the printer and the insert the paper in the paper in slot. The printer will automatically pull the paper. This printer is used in machines like video lottery terminals to print receipts. It can receive print jobs from either USB full speed or RS-232.

Operational frequencies

192 MHz internal to the processor, 96 MHz for memory access.

Software details

Printer firmware version HSV-5.50F

3.4 EUT exercise and monitoring details

To put the paper, power the printer and the insert the paper in the paper in slot. The printer will automatically pull the paper. Press the paper feed button (on the base top) for at least 6 seconds. The printer will start printing continuously until powered off. For ESD testing, the printer could reset immediately after a discharge. In that case, the printing will stop. The paper feed button needs to be pressed again for 6 seconds. Sometime, after an ESD discharge, if the processor is locked up, the internal watchdog timer will reset the printer after about 30 seconds.

3.5 EUT setup details

Table 3.5-1: EUT sub assemblies

Description	Brand name	Model/Part number	Serial number	Rev.
HSV L Thermal Printer	Nanoptix Inc	HSV L™ / 950100	VL00160	---
ITE Power Supply	GlobTek, Inc.	GT-21126-6024 / GS-1110	RoHS021647013811	---

Table 3.5-2: EUT interface ports

Description	Qty.
DC Power Input	1
RS-232 (DB9 Female Connector)	1
USB (mini-B Connector)	1

Table 3.5-3: Support equipment

Description	Brand name	Model/Part number	Serial number	Rev.
Laptop Computer	Dell	Latitude D600	CN-0G5152-48643-445-0906	A01

Table 3.5-4: Inter-connection cables

Cable description	From	To	Length (m)
2 Conductor DC Power Cable	EUT	AC/DC Power Adapter	2
DB9 to DB9 Null Cable	EUT	Laptop Computer or Underminated	2
Mini-B to Standard USB Cable	EUT	Laptop Computer or Underminated	2

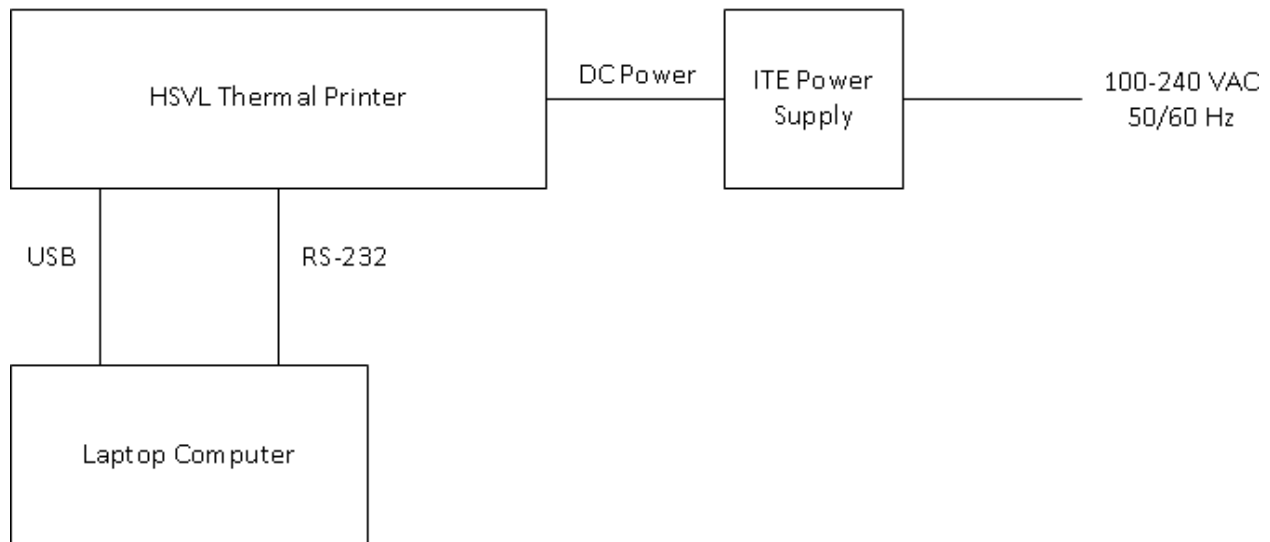

Diagram 3.5-1: Setup diagram



Section 4 Engineering considerations

4.1 Modifications incorporated in the EUT

There were no modifications performed to the EUT during this assessment.

4.2 Technical judgment

None

4.3 Deviations from laboratory tests procedures

No deviations were made from laboratory procedures.

Section 5 Test conditions

5.1 Atmospheric conditions

Temperature: 15–30 °C
Relative humidity: 20–75 %
Air pressure: 86–106 kPa

When it is impracticable to carry out tests under these conditions, a note to this effect stating the ambient temperature and relative humidity during the tests shall be recorded and stated.

5.2 Power supply range

The normal test voltage for equipment to be connected to the mains shall be the nominal mains voltage. For the purpose of the present document, the nominal voltage shall be the declared voltage, or any of the declared voltages $\pm 5\%$, for which the equipment was designed.

Section 6 Measurement uncertainty

6.1 Uncertainty of measurement

Nemko Canada Inc. has calculated measurement uncertainty and is documented in EMC/MUC/001 "Uncertainty in EMC measurements." Measurement uncertainty was calculated using the methods described in CISPR 16-4 Specification for radio disturbance and immunity measuring apparatus and methods – Part 4: Uncertainty in EMC measurements; as well as described in UKAS LAB34: The expression of Uncertainty in EMC Testing. Measurement uncertainty calculations assume a coverage factor of $K=2$ with 95% certainty.

Section 7 Terms and definitions

7.1 Performance terms and definitions

The manufacturer has the obligation to express the performance criteria in terms which relate to the performance of his specific product when used as intended. The following performance criteria are applicable, and shall only be evaluated when the functions referred to are implemented.

General performance criteria

Examples of functions defined by the manufacturer to be evaluated during testing include, but are not limited to, the following:

- essential operational modes and states;
- tests of all peripheral access (hard disks, floppy disks, printers, keyboard, mouse, etc.);
- quality of software execution;
- quality of data display and transmission;

Performance criterion A

The equipment shall continue to operate as intended without operator intervention. No degradation of performance or loss of function is allowed below a performance level specified by the manufacturer when the equipment is used as intended. The performance level may be replaced by a permissible loss of performance. If the minimum performance level or the permissible performance loss is not specified by the manufacturer, then either of these may be derived from the product description and documentation, and by what the user may reasonably expect from the equipment if used as intended.

Performance criterion B

After the test, the equipment shall continue to operate as intended without operator intervention. No degradation of performance or loss of function is allowed, after the application of the phenomena below a performance level specified by the manufacturer, when the equipment is used as intended. The performance level may be replaced by a permissible loss of performance.

During the test, degradation of performance is allowed. However, no change of operating state or stored data is allowed to persist after the test.

If the minimum performance level (or the permissible performance loss) is not specified by the manufacturer, then either of these may be derived from the product description and documentation, and by what the user may reasonably expect from the equipment if used as intended.

Performance criterion C

Loss of function is allowed, provided the function is self-recoverable, or can be restored by the operation of the controls by the user in accordance with the manufacturer's instructions.

Functions, and/or information stored in non-volatile memory, or protected by a battery backup, shall not be lost.

Section 8 Testing data

8.1 Radio-frequency electromagnetic field amplitude modulated

8.1.1 References

EN 61000-4-3: 2006 + A1: 2008 + A2: 2010

8.1.2 Test summary

Verdict Pass

8.1.3 Observations/special notes

The EUT was set up as table top configuration.

8.1.4 Test equipment list

Table 8.1-1: Radio-frequency electromagnetic field amplitude modulated equipment list

Equipment	Manufacturer	Model no.	Asset no.	Cal./Ver. cycle	Next Cal./Ver.
Bilog antenna	Sunol	JB3	FA002108	1 year	Jan. 31/12
E-Field probe 3 MHz to 18 GHz	AR	FP7018	FA002185	1 year	May 25/12
Dir. coupler 80 to 1000 MHz	AR	DC6180	FA001659	1 year	Aug. 15/12
Power meter	Rhode & Schwarz	NRP	FA002076	1 year	Sept. 06/12
Power sensor	Rhode & Schwarz	NRP-Z91	FA002075	1 year	Sept. 06/12
Signal generator	Rhode & Schwarz	SMB100A	FA002174	1 year	Jan. 26/12
Amp. (80 MHz–1 GHz, 250 W)	AR	250W1000A	FA002038	—	NCR
Note: NCR - no calibration required					

8.1.5 Test data

Test date October 29, 2011 Test engineer Daniel Hynes
 Temperature 20 °C Air pressure 1015 mbar Relative humidity 32 %

Table 8.1-2: Radio-frequency electromagnetic field amplitude modulated results

Swept frequency range (MHz)		Test level (V/m r.m.s.)	EUT position facing antenna	Antenna polarization	Comments
Start	Stop				
80	1000	3	Front side	Vertical	No degradation
				Horizontal	
			Back side	Vertical	
				Horizontal	
			Left side	Vertical	
				Horizontal	
			Right side	Vertical	
				Horizontal	

Notes:

- The test CW signal was amplitude modulated (AM) with 80 % depth with a 1 kHz sine wave.
- The dwell time of the modulated carrier at each frequency was set to 3 seconds.
- The frequency range was swept incrementally with a step size of 1 %.
- EUT operational frequencies within specified test band were also assessed.
- For TTE and Facsimile devices an additional comprehensive functional test was carried out at a limited number of frequencies. The selected frequencies were: 80, 120, 160, 230, 434, 460, 600, 863, and 900 MHz (± 1 %).



8.1.6 Setup photos

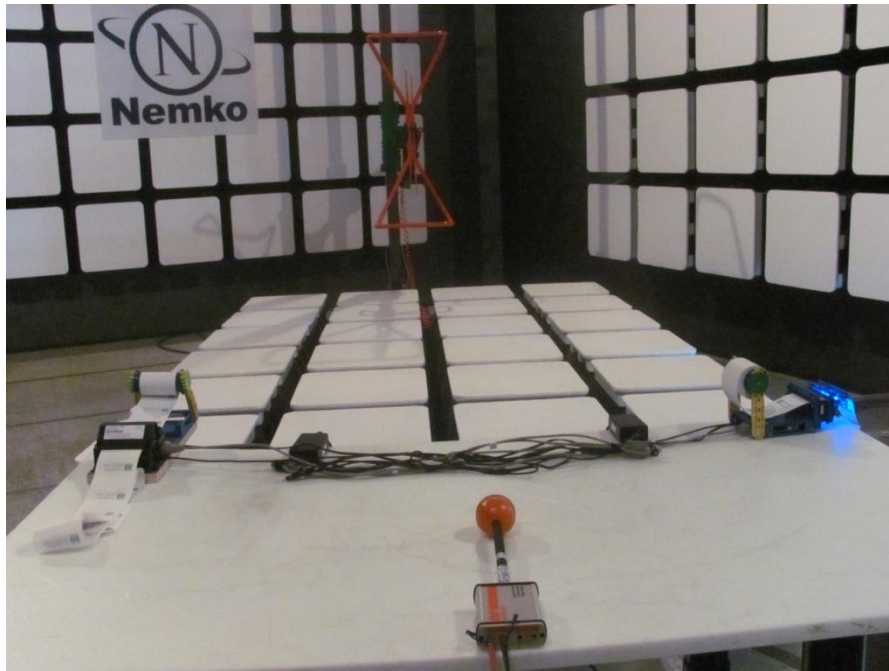

Photo 8.1-1: Radio-frequency electromagnetic field amplitude modulated setup

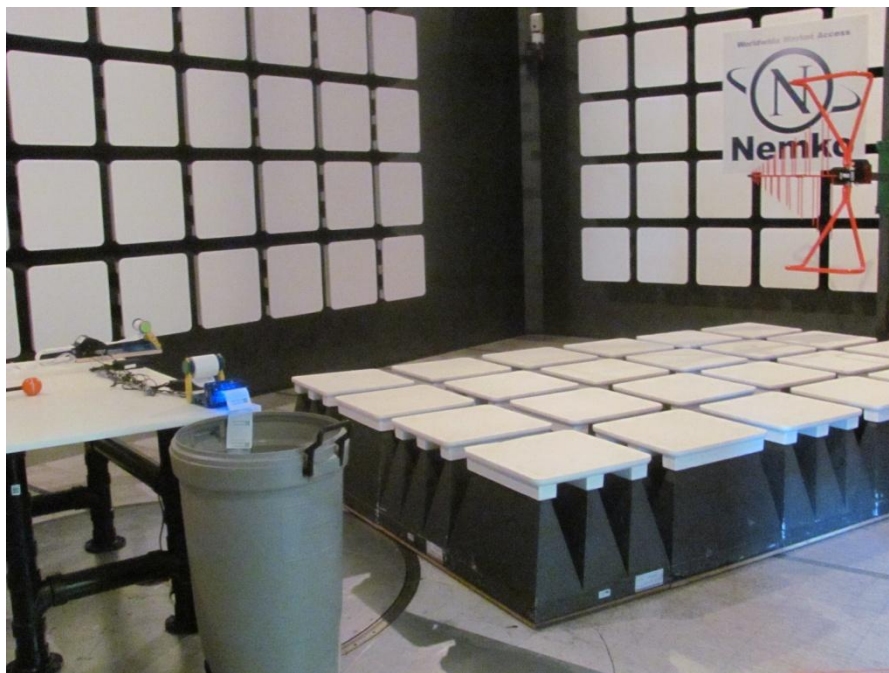

Photo 8.1-2: Radio-frequency electromagnetic field amplitude modulated setup

8.2 Radio-frequency continuous conducted

8.2.1 References

EN 61000-4-6: 2009

8.2.2 Test summary

Verdict Pass

8.2.3 Observations/special notes

None

8.2.4 Test equipment list

Table 8.2-1: Radio-frequency continuous conducted equipment list

Equipment	Manufacturer	Model no.	Asset no.	Cal./Ver. cycle	Next Cal./Ver.
Amplifier	AR	75A250A	FA001943	—	NCR
Signal generator	Rhode & Schwarz	SML-03	FA002046	1 year	Mar. 22/12
6 dB Attenuator	Inmet	64671	FA002215	1 year	Sept. 07/12
CDN-M3	FCC	FCC-801-M3-16A	FA002065	1 year	May 31/12
EM injection clamp	FCC	F-2031-23MM	FA001762	1 year	May 06/12
Current clamp	Tegam	95236-1	FA000698	1 year	Feb. 08/12
Power meter	Rhode & Schwarz	NRP	FA002070	1 year	Dec. 07/11
Power sensor	Rhode & Schwarz	NRP-Z91	FA002107	1 year	Dec. 07/11

Note: NCR - no calibration required

8.2.5 Test data

Test date October 27, 2011 **Test engineer** Daniel Hynes
Temperature 22 °C **Air pressure** 1001 mbar **Relative humidity** 23 %

Table 8.2-2: Radio-frequency continuous conducted results

Swept frequency range (MHz)		Test level (V r.m.s.)	Ports investigated	Coupling Method	Comments
Start	Stop				
0.15	80	3	AC Mains	CDN	No degradation
			USB	EM Clamp	No degradation
			RS-232	EM Clamp	No degradation

Notes:

- The test CW signal was amplitude modulated (AM) with 80 % depth with a 1 kHz sine wave.
- The dwell time of the modulated carrier at each frequency was set to 6 seconds.
- The frequency range was swept incrementally with a step size of 1 %.
- EUT operational frequencies within specified test band were also assessed.
- Applicable to signal ports and telecommunication ports cables which according to the manufacturer's specification supports communication on cable lengths greater than 3m.
- For TTE and Facsimile devices an additional comprehensive functional test was carried out at a limited number of frequencies. The selected frequencies were: 0.2, 1, 7.1, 13.56, 21, 27.12 and 40.68 MHz (±1 %).



8.2.6 Setup photos

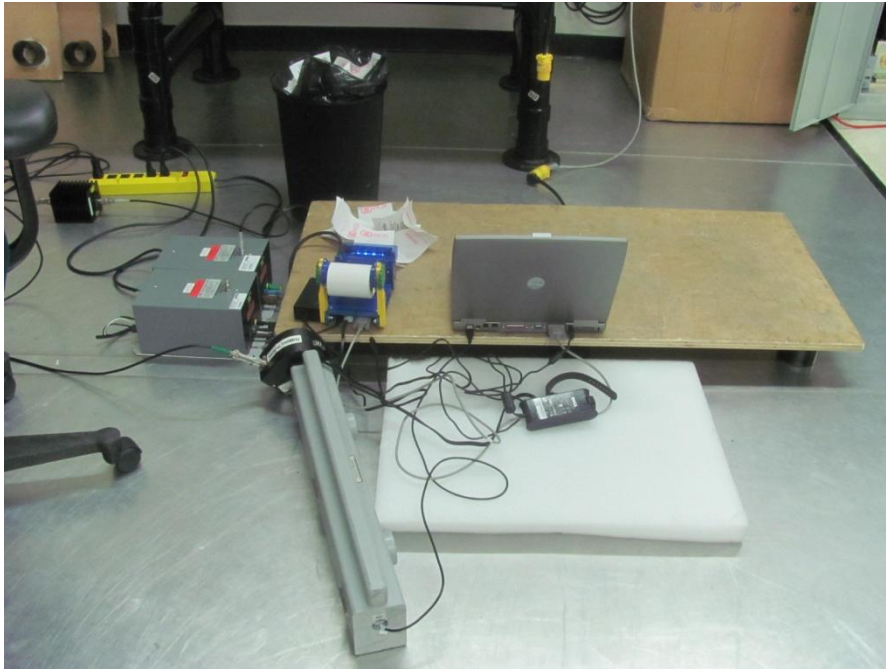

Photo 8.2-1: Radio-frequency continuous conducted setup

8.3 Electrostatic discharge

8.3.1 References

EN 61000-4-2: 2009

8.3.2 Test summary

Verdict Pass

8.3.3 Observations/special notes

- The EUT was set up as table top configuration.
- Repetition rate of discharge was applied at 1 pulse per second.
- Elevated test levels performed as requested by the customer

8.3.4 Test equipment list

Table 8.3-1: Electrostatic discharge equipment list

Equipment	Manufacturer	Model no.	Asset no.	Cal./Ver. cycle	Next Cal./Ver.
ESD gun	Keytek	MZ-15/EC	FA001983	1 year	Feb. 08/12

8.3.5 Test data

Test date October 30, 2011 **Test engineer** Daniel Hynes
Temperature 23 °C **Air pressure** 1004 mbar **Relative humidity** 37 %

Table 8.3-2: Electrostatic discharge results

Contact discharge	Discharges	Test voltage (±kV)	Comments
Please refer to "Electrostatic discharge test location points" photos of this section	25	2, 4, 6, 8	No degradation
Indirect discharge	Discharges	Test voltage (±kV)	Comments
HCP (All sides)	25	2, 4, 6, 8	No degradation
VCP (All sides)	25	2, 4, 6, 8	No degradation
Air discharge	Discharges	Test voltage (±kV)	Comments
Please refer to "Electrostatic discharge test location points" photos of this section	10	2, 4, 8	No degradation
Please refer to "Electrostatic discharge test location points" photos of this section	10	15	See Notes

Notes: EUT partial reset (power light turned red and the printer re-initialized); unit considered to have recovered with user intervention as it was responsive to commands and printed upon command immediately after partial reset with the pressing of the power button to initialize continuous printing once again. This test level is also beyond the requirements of this standard but applied as per the request of the customer.

8.3.6 Test data, continued

Electrostatic discharge test location points

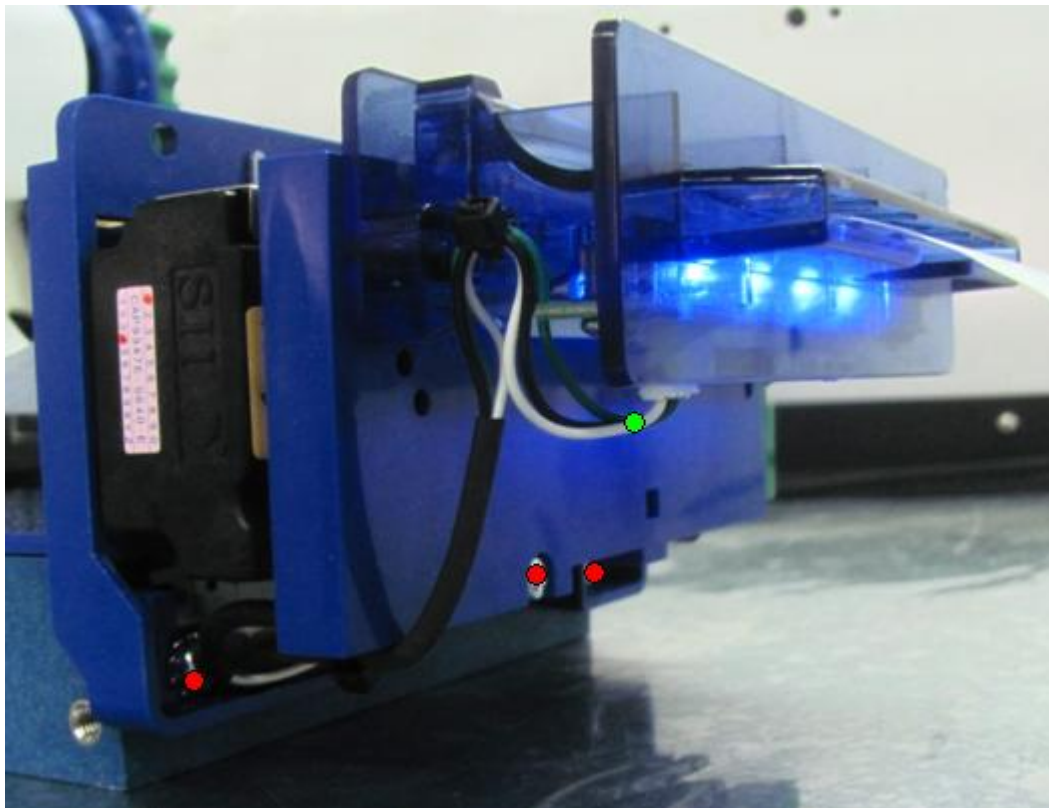
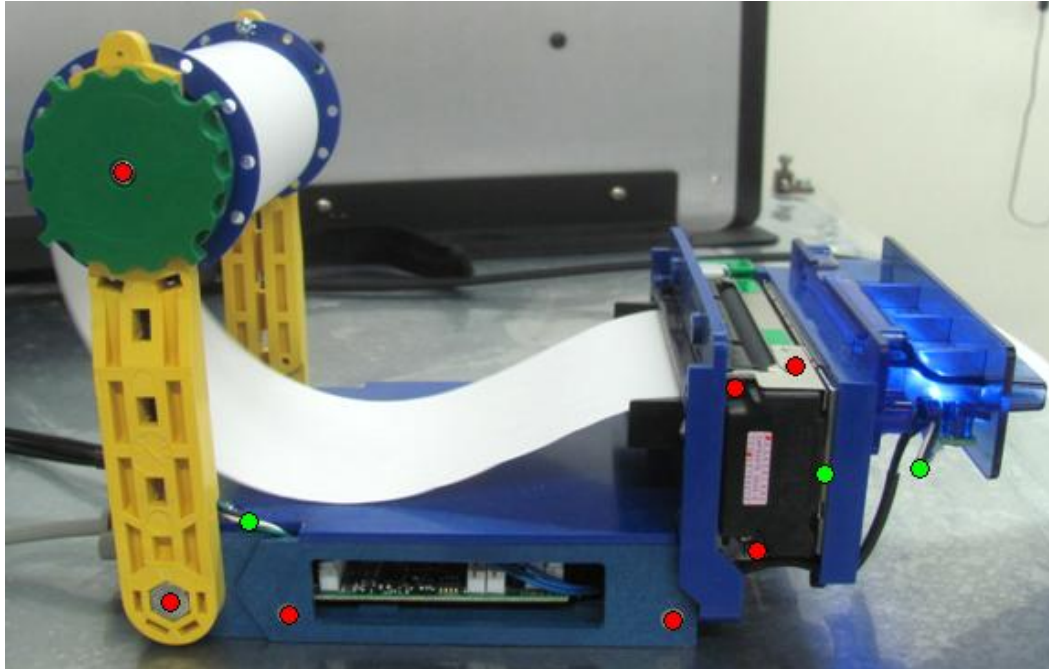

Red points = contact discharge

Green points = Air discharge

8.3.5 Test data, continued

Electrostatic discharge test location points

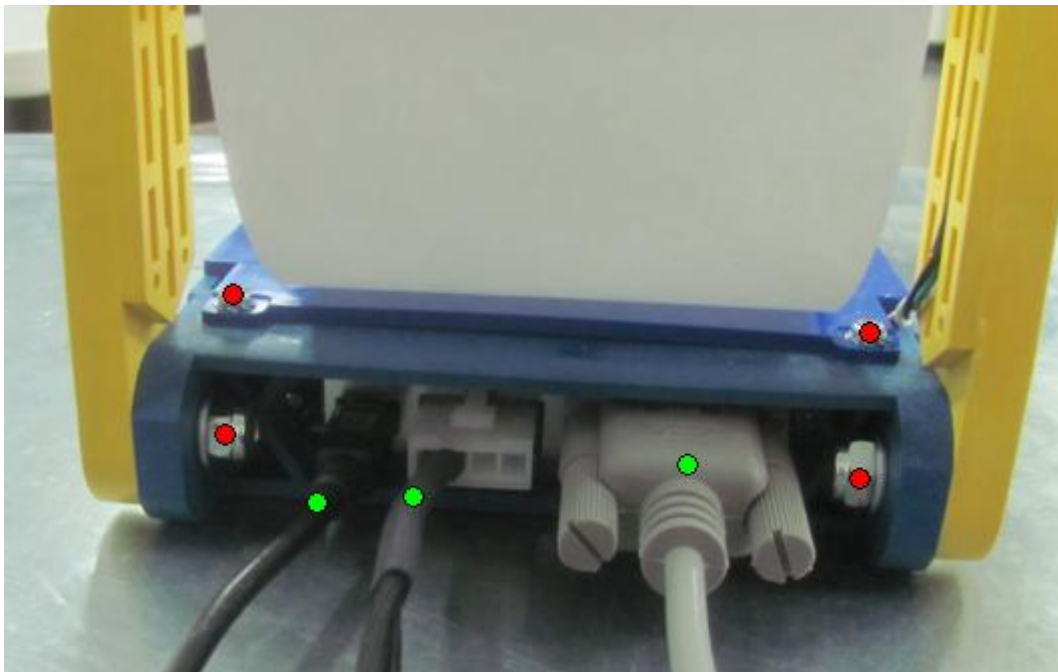
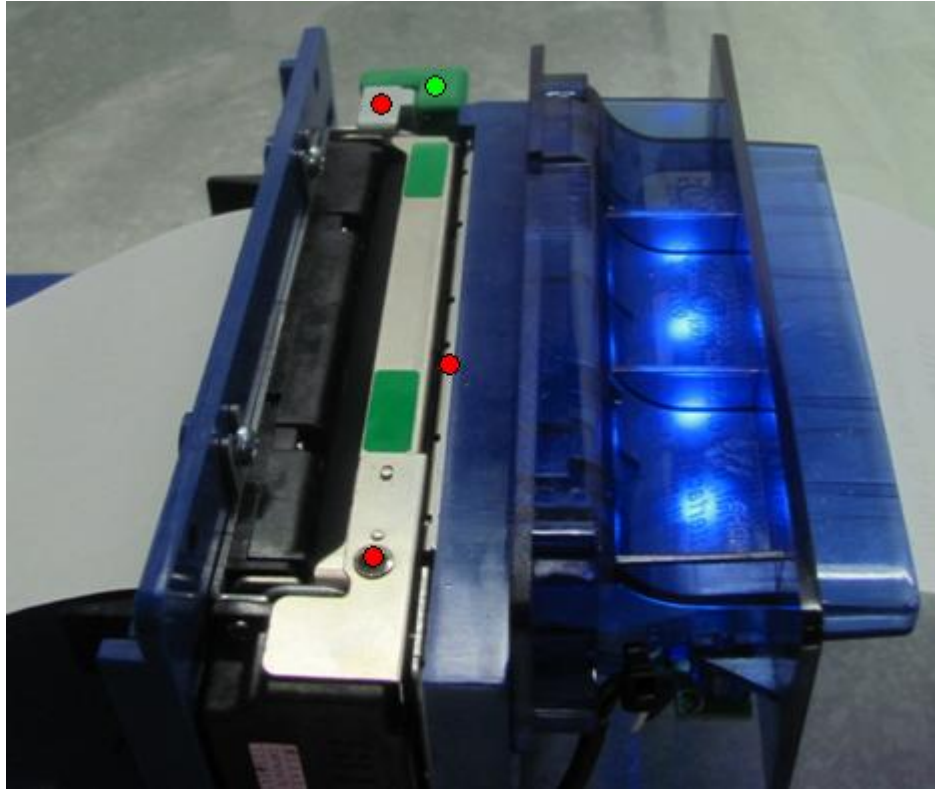

Red points = contact discharge

Green points = Air discharge

8.3.5 Test data, continued

Electrostatic discharge test location points

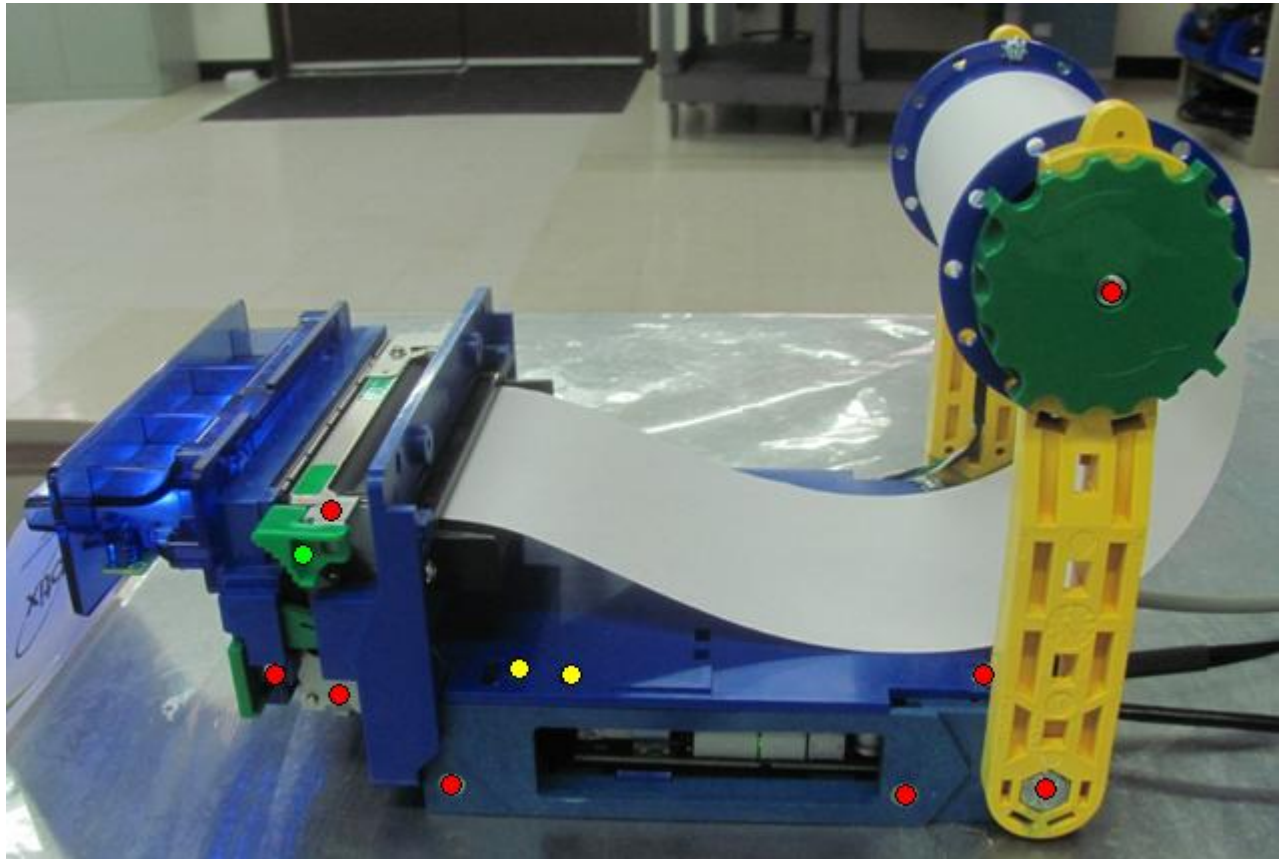

Red points = contact discharge

Green points = Air discharge

Yellow points = 15 kV Air Discharge EUT Reset

8.3.6 Setup photos



Photo 8.3-1: Electrostatic discharge setup



Photo 8.3-2: Electrostatic discharge setup

8.4 Surge

8.4.1 References

EN 61000-4-5: 2006

8.4.2 Test summary

Verdict Pass

8.4.3 Observations/special notes

None

8.4.4 Test equipment list

Table 8.4-1: Surge equipment list

Equipment	Manufacturer	Model no.	Asset no.	Cal./Ver. cycle	Next Cal./Ver.
Control Centre	KeyTek	ECAT™ E-Class Series 100	FA000739	—	VOU
EFT/SURGE Coupler/Decoupler	KeyTek	E4551	FA000742	—	VOU
Surge Network Module	KeyTek	E501	FA000741	—	VOU
Note: VOU - verify on use					

8.4.5 Test data

Test date October 28, 2011 **Test engineer** Daniel Hynes
Temperature 22 °C **Air pressure** 1010 mbar **Relative humidity** 25 %

Table 8.4-2: Surge results

Waveform parameters (µs)		Surge pulse interval (s)	Number of pulses	
Open circuit voltage (T ₁ /T ₂)	Short circuit current (T ₁ /T ₂)		Positive	Negative
1.2/50	8/20	30	5	5
Wave shape of pulse: T ₁ = front time, T ₂ = time to half value				
Input AC power ports	Coupling	Test voltage ±(kV)	Comments	
AC Mains	Phase to Neutral	0.5, 1	No degradation	
	Phase to ground	0.5, 1, 2	No degradation	
	Neutral to ground	0.5, 1, 2	No degradation	
Notes:				
<ul style="list-style-type: none"> - Line to line: Surge applied with generator output impedance set to 2 Ω - Line to ground: Surge applied with generator output impedance set to 12 Ω - Surge applied synchronous (relation to power supply): 0, 90, 180, and 270° 				

8.4.6 Setup photos



Photo 8.4-1: Surge setup

8.5 Fast transients

8.5.1 References

EN 61000-4-4: 2004 + A1: 2010

Special Note: A more relevant publication of EN 61000-4-4 has been applied for this assessment.

8.5.2 Test summary

Verdict Pass

8.5.3 Observations/special notes

None

8.5.4 Test equipment list

Table 8.5-1: Fast transients equipment list

Equipment	Manufacturer	Model no.	Asset no.	Cal./Ver. cycle	Next Cal./Ver.
Control Centre	KeyTek	ECAT™ E-Class Series 100	FA000739	—	VOU
EFT/Burst Module	KeyTek	E411	FA000740	—	VOU
Capacitive Clamp	KeyTek	CCL-4/S	FA000743	—	NCR
EFT/SURGE Coupler/Decoupler	KeyTek	E4551	FA000742	—	VOU

Notes:

- VOU - verify on use
- NCR - no calibration required

8.5.5 Test data

Test date October 28, 2011 **Test engineer** Daniel Hynes
Temperature 22 °C **Air pressure** 1010 mbar **Relative humidity** 25 %

Table 8.5-2: Fast transients results

Characteristic of fast transient				
Wave shape Tr/Td (ns)	Repetition frequency (kHz)	Burst duration (ms)	Burst period (ms)	Test duration (s)
5/50	5	15	300	60
Wave shape of pulse: Tr = rise time, Td= duration time Transient applied asynchronous (relation to power supply)				
Input AC power ports		Test voltage ±(kV)	Comments	
AC Mains		0.5, 1	No degradation	
Notes: The test voltage was applied simultaneously between a ground reference plane and all of the power supply terminals and the protective or functional earth port on the EUT cabinet.				
Signal and telecommunication ports		Test voltage ±(kV)	Comments	
USB		0.5	No degradation	
RS-232		0.5	No degradation	
Notes: – The test voltage was applied via capacitive coupling clamp. – Applicable to signal ports and telecommunication ports cables which according to the manufacturer's specification supports communication on cable lengths greater than 3m.				

8.5.6 Setup photos

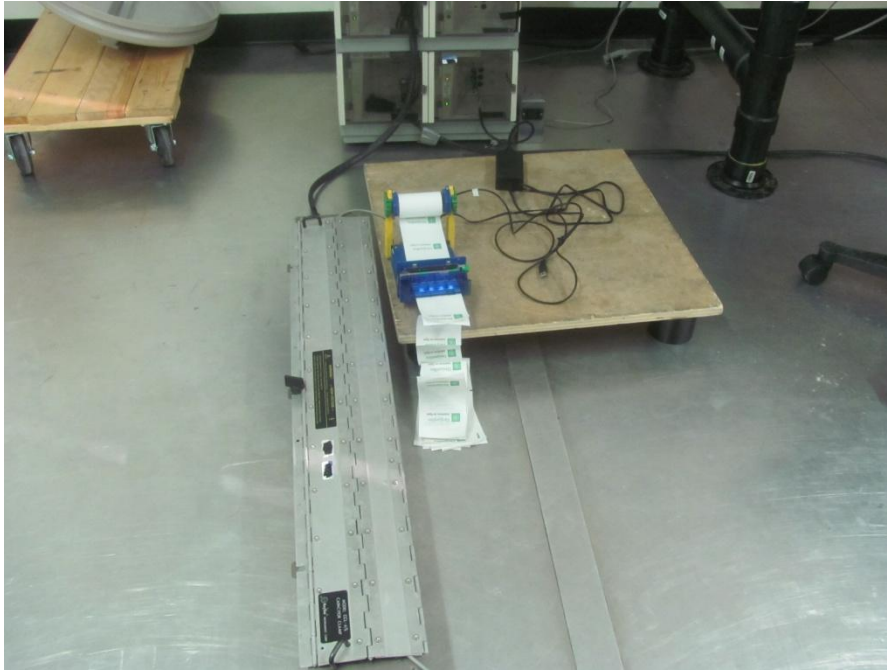

Photo 8.5-1: Fast transients setup

8.6 Voltage dips and voltage interruptions

8.6.1 References

EN 61000-4-11: 2004

8.6.2 Test summary

Verdict Pass

8.6.3 Observations/special notes

None

8.6.4 Test equipment list

Table 8.6-1: Voltage dips and voltage interruptions equipment list

Equipment	Manufacturer	Model no.	Asset no.	Cal./Ver. cycle	Next Cal./Ver.
Power source	California Instruments	5001IX	FA001238	1 year	March 9/12
Electronic output switch	California Instruments	EOS-1	FA002253	1 year	March 9/12

8.6.5 Test data

Test date October 29, 2011
Temperature 20 °C

Test engineer Daniel Hynes
Air pressure 1015 mbar

Relative humidity 32 %

Table 8.6-2: Voltage dips and voltage interruptions results

Voltage dips			
Test port	Voltage reduction (%)	Periods	Comments
AC Mains	100	0.5	No degradation
	60	25	No degradation
Voltage interruptions			
Test port	Voltage reduction (%)	Periods	Comments
AC Mains	100	250	EUT power cycled.
Notes:			
<ul style="list-style-type: none"> - Changes occurred at the 0 crossings of the voltage waveform. - The EUT was tested for each selected combination of test level and duration with a sequence of three dips/interruptions with an interval of 10 seconds between each test. 			

8.6.6 Setup photos

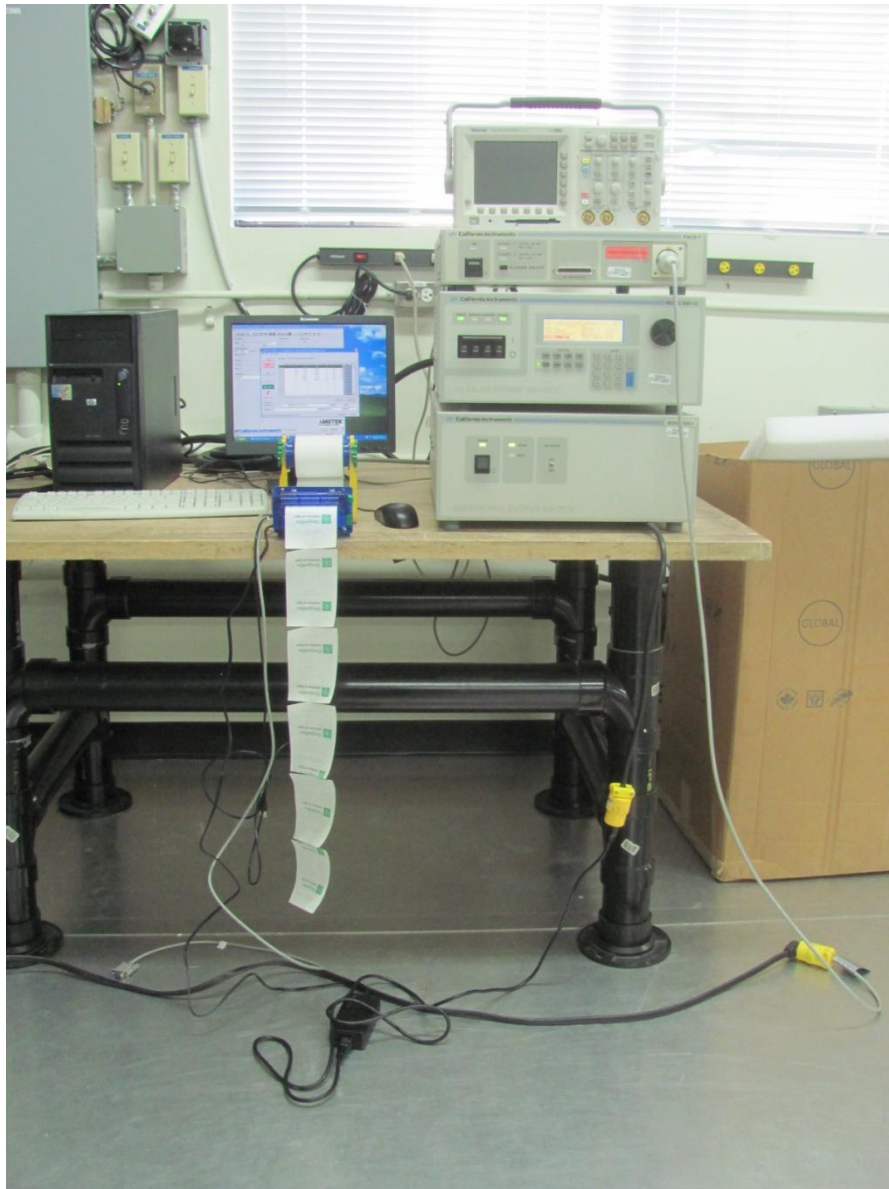
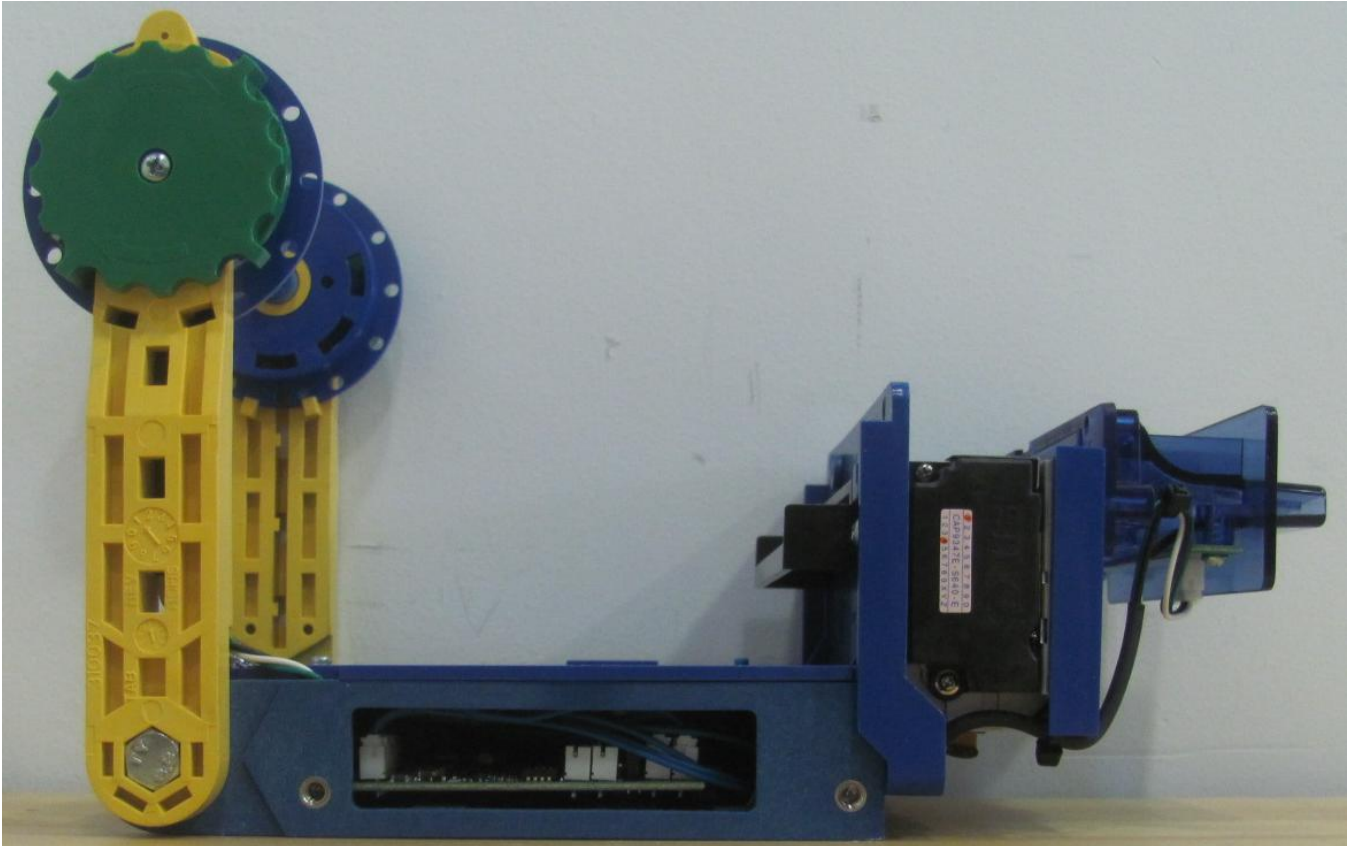

Photo 8.6-1: Voltage dips and voltage interruptions setup

Section 9 EUT photos

9.1 External photos

9.1.1 Side View



9.1.2 Front Paper Exit View

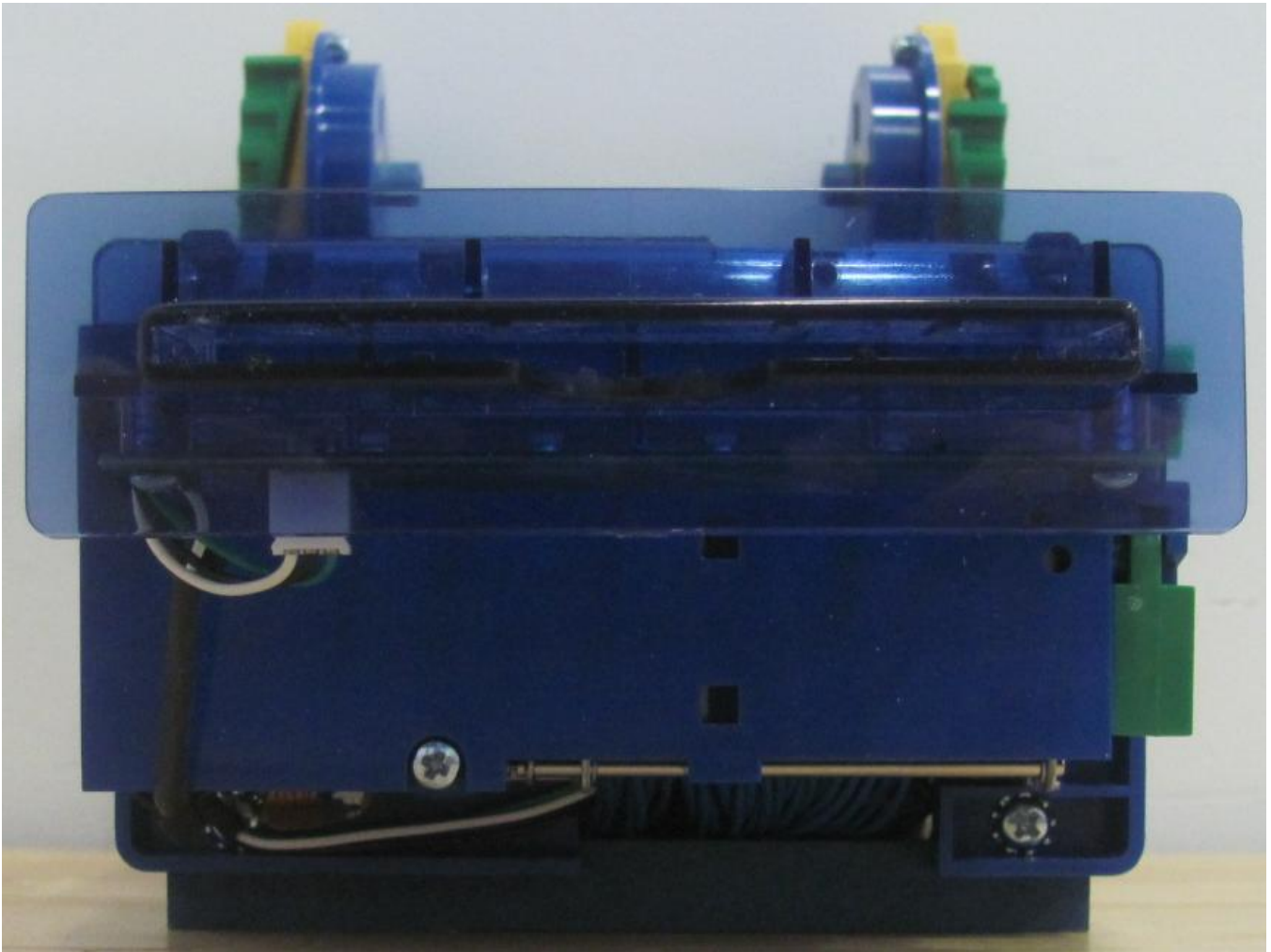

9.1.3 Side View

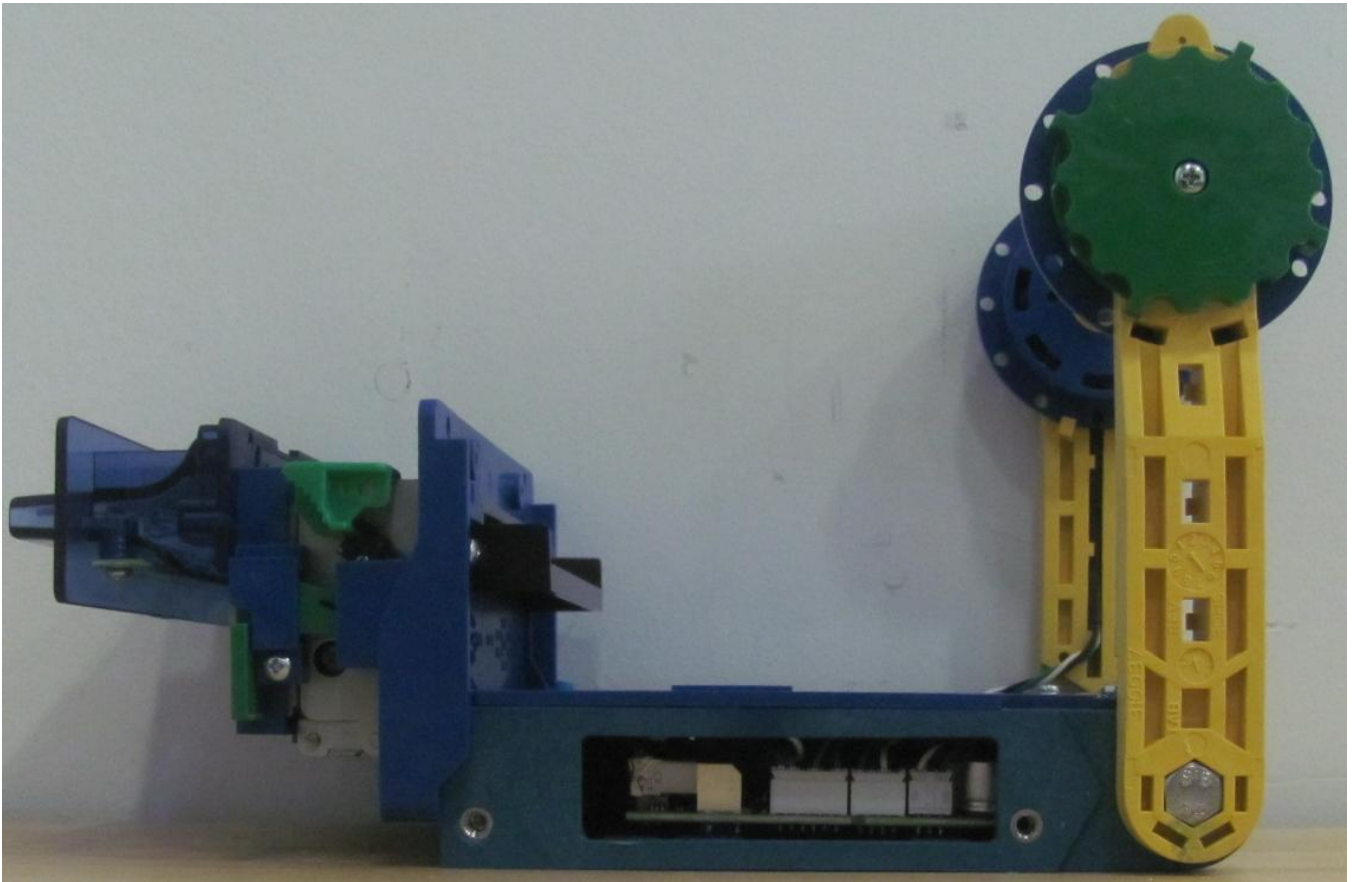

9.1.4 Connector Side View

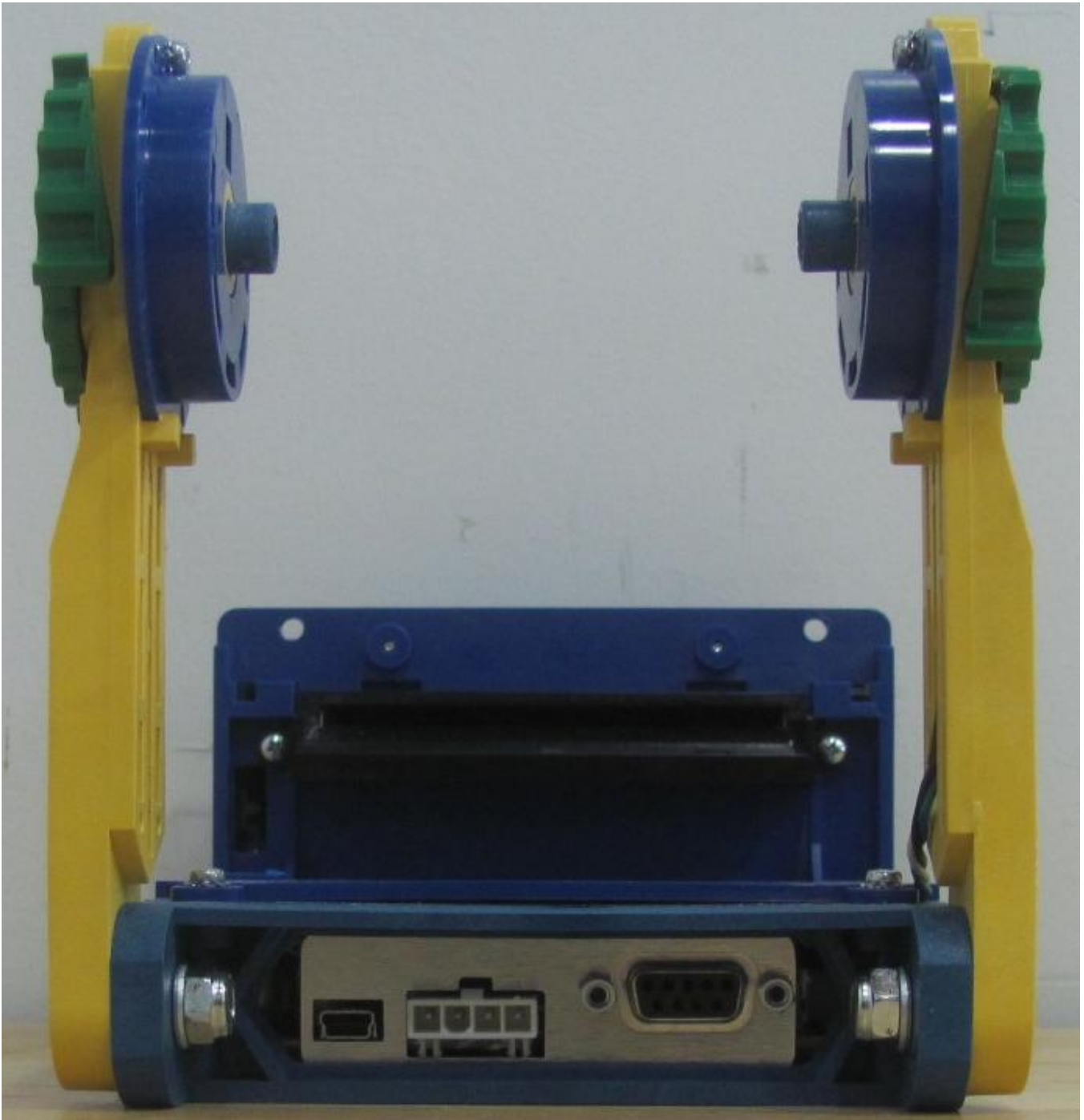

9.1.5 Bottom View



9.1.6 Top View

